

CYLINDERS



PUMP CAPACITY

Selection Chart

Choose the Right Pump
Choose the Right Tonnage,
stroke and retracted height

The Following guidelines are for general lifting and construction applications. Hydraulic tools, pullers and presses may fall outside these

recommendations. Always check to see that the pump's "usable reservoir capacity" exceeds the cylinder(s) oil Capacity.

Generally Recommended



Marginal Check Requirements



Not Recommended for most applications



10,000 psi Maximum Working Pressure

	PUMP MODEL	STROKE	CYLINDER CAPACITY (Tons)																				
			PRESSURE STAGE																				
			5	10	15	20	25	30	55	75	100	150	200	300	400	500							
	46	P12‡	Single	14	32	44	65	72	93														
	46	P55‡	Single	6	14	19	28	31	40	71													
	47	P19/ P19L	Low	4	8	10	15	17	21														
			High	13	30	42	59	68	86														
	47	P59F	Low	1.8	4.1	5.7	8	9	12	20	29												
			High	8	17	24	34	48	50	85	122												
	47	P59(L)‡	Low	1.5	3.2	4.7	7	7.7	9.7	16.7	23.9												
	48	P157‡	High	6	14	19	28	31	40	71	101												
	48	P159‡	Low	0.5	1	1.3	1.9	2.2	2.8	5	7	9	13	18									
	48	P300‡	High	7	15	21	30	34	43	77	110	143	200	250									
48	P460‡	Low	0.1	0.3	0.6	0.6	0.7	0.9	1.5	2.2	2.8	4.2	5.6	8.4	11.2								
		High	3.3	7.7	9	14	17.5	22	37	55	71	105	143	213	284								
	68	PE10	Low	0.5	1.2	1.6	2.2	2.6	3.2	5.5													
			High	6	13.4	18.9	27	31	39	66.2													
	70	PE17‡	Low	0.2	0.5	0.7	0.9	1.1	1.4	2.3	3.3	4.3	6.5	8.7									
			High	3.5	7.9	10.9	16	18	23	39	56.3	73	109	146									
	72-73	PE18	Low	0.4	0.8	1.2	1.6	1.8	2.3	3.9	5.7	7.3	10.8	14.6	21.9	29.2							
			High	3.3	7.5	10.3	15	17	21	37	53	69	102	136	207	276							
	74-75	PE21‡	Low	0.2	0.5	0.7	1.0	1.1	1.4	2.5	3.6	4.6	6.8	9.2	13.8	18.4							
			High	2.8	6.4	9	13	15	19	32	45.5	59	88	118	177	236							
	76-77	PED25	Low	0.2	0.4	0.6	0.9	1.0	1.3	2.2	3.2	4.1	6.1	8.3	12.0	15.7	19.9						
			High	2.4	5.4	7.5	10.6	12.4	15.6	26.5	38.2	49.5	73.6	99.1	144.3	188.5	238.6						
	78-79	PE30‡	Low	0.2	0.45	0.6	0.9	1	1.3	2.2	3.2	4.1	6										
			High	2	4.5	6	9	10	13	22	32	41	60										
	80-81	PE46‡	Low	0.1	0.3	0.4	0.5	0.6	0.7	1.3	1.8	2.4	3.5	4.7	7.2	9.6							
			High	1.3	2.9	4.1	5.9	6.8	8.6	14	22	28	42	56	84	112							
82-83	PE55‡	Low	0.1	0.2	0.3	0.4	0.4	0.6	0.9	1.4	1.8	2.6	3.5	5.4	7.2								
84-85	PE60‡	High	1.1	2.4	3.4	4.8	5.6	7.1	12	17.8	23	34	45	69	92								
86-87	PQ60	Low	0.1	0.2	0.3	0.4	0.4	0.5	0.9	1.3	1.7	2.5	3.4	5.1	6.8	8.5							
		High	1	2.2	3.3	4.4	5.2	6.5	11	16.2	21	31	41	63	84	105							
88-89	PQ120	Low	0.1	0.2	0.3	0.4	0.4	0.5	0.9	1.3	1.7	2.5	3.4	5.1	6.8	8.5							
		High	0.5	1.1	1.6	2.2	2.6	3.2	5.5	7.7	10	15	21	30	40	50							
90-91	PE400	Low	0.1	0.1	0.2	0.2	0.3	0.3	0.6	8	1	1.5	2.1	3	4	5							
		High	0.1	0.3	0.4	0.6	0.7	0.9	1.6	2.2	2.9	4.4	5.9	8.7	11.6	14.5							
	50-51	PA6‡	Single	10	22.4	31	44.4	51.3	65.2														
	54-55	PA9‡	Single	10	22.4	31	44.4	51.3	65.2														
	60-61	PA17‡	Low	0.2	0.5	0.7	0.9	1.1	1.4	2.3	3.3	4.3	6.5	8.7									
			High	3.5	7.9	10.9	16	18	23	39	56	73	109	146									
	62-63	PA46‡	Low	0.1	0.3	0.4	0.5	0.6	0.7	1.3	2	2.4	3.5	4.7	7.2	9.6							
			High	1.3	2.9	4.1	5.9	6.8	8.6	14	22	28	56	42	84	112							
62-63	PA55‡	Low	0.1	0.3	0.4	0.6	0.7	0.9	1.5	2.2	2.8	4.1	5.5	8.4	11.2								
		High	1.1	2.4	3.4	4.8	5.6	7.1	12	18	23	34	45	69	92								
	94-95	PG30	Low	0.3	0.7	1	1.3	1.6	2	3.3	4.8	6.2	9.3	12.4	18.1								
			High	2	4.5	6.3	8.9	10.3	13	22	31.8	41.3	61.4	83	121								
	94	PG55‡	Low	0.1	0.3	0.4	0.6	0.7	0.8	1.4	2	2.6	3.9	5.2	7.6	9.9	12.5						
			High	1.1	2.5	3.5	4.9	5.6	7.1	12.1	17.3	22.5	33.5	45	66	86	109						
	96-97	PG120‡	Low	0.1	0.3	0.4	0.6	0.7	0.8	1.4	2	2.6	3.9	5.2	7.6	9.9	12.5						
			High	0.5	1.0	1.5	2.0	2.4	3.0	5.1	7.3	9.5	14.2	19.1	27.8	36.3	46.0						
96-97	PG400	Low	0.1	0.1	0.2	0.2	0.3	0.3	0.6	0.8	1.0	1.5	2.0	3.0	3.8	4.9							
		High	0.2	0.3	0.5	0.7	0.8	1.0	1.7	2.4	3.1	4.6	6.2	9.0	11.8	15.0							

‡ Some Power Team pumps are available in special configurations not listed in this catalog. Power Team can "Assemble to order" pumps with special seals, voltages, valves, relief valve settings, etc. For your special requirements please consult your local distributor or the Power Team factory.

* Hand Pumps = Number of strokes required to move piston 1". † Air, Electric and Gasoline Engine/Hydraulic pumps = Number of seconds required to move piston 1".

Re-tracted				Re-tracted			
Stroke (in.)	Height (in.)	Order No.	Page No.	Stroke (in.)	Height (in.)	Order No.	Page No.

2 ton pull	5	9 ³ / ₁₆	RP25	23
5 ton pull	5 ¹ / ₂	11 ⁷ / ₈	RP55	23
	9 ¹ / ₁₆	1 ⁵ / ₈	RLS50	18
	1	4 ³ / ₈	C51C	15
5 Ton	3 ¹ / ₄	6 ¹ / ₂	C53C	15
	5 ¹ / ₄	8 ¹ / ₂	C55C	15
	5 ¹ / ₄	10 ¹ / ₂	C55CBT	16
	7 ¹ / ₄	10 ³ / ₄	C57C	15
	9 ¹ / ₄	12 ³ / ₄	C59C	15

10 Ton	7 ¹ / ₁₆	1 ³ / ₄	RLS100	18
	1	3 ⁵ / ₈	C101C	15
	1 ¹ / ₂	3 ¹ / ₂	RSS101	19
	2 ¹ / ₈	4 ³ / ₄	C102C	15
	2 ¹ / ₂	5 ¹ / ₄	RH102	18
	4 ¹ / ₈	6 ³ / ₄	C104C	15
	6 ¹ / ₈	9 ³ / ₄	C106C	15
	6 ¹ / ₈	11 ¹ / ₂	C106CBT	16
	6 ¹ / ₄	11 ¹¹ / ₁₆	RD106	23
	8	11 ⁵ / ₁₆	RH108	20
8 ¹ / ₈	11 ³ / ₄	C108C	15	
10	15 ¹¹ / ₁₆	RD1010	25	
10 ¹ / ₈	13 ³ / ₄	C1010C	15	
10 ¹ / ₈	15 ¹ / ₂	C1010CBT	16	
12 ¹ / ₈	15 ³ / ₄	C1012C	15	
14 ¹ / ₈	17 ³ / ₄	C1014C	15	

12 Ton	5 ¹ / ₁₆	2 ³ / ₁₆	RH120	20
	1 ⁵ / ₈	4 ¹³ / ₁₆	RH121	20
	1 ⁵ / ₈	4 ¹³ / ₁₆	RH121T	20
	3	7 ¹ / ₄	RH123	20

15 Ton	1	4 ⁷ / ₈	C151C	15
	2 ¹ / ₈	5 ⁷ / ₈	C152C	15
	4 ¹ / ₈	7 ⁷ / ₈	C154C	15
	6 ¹ / ₈	10 ¹¹ / ₁₆	C156C	15
	8 ¹ / ₈	12 ¹¹ / ₁₆	C158C	15
	10 ¹ / ₈	14 ¹¹ / ₁₆	C1510C	15
	12 ¹ / ₈	16 ¹¹ / ₁₆	C1512C	15
	14 ¹ / ₈	18 ¹¹ / ₁₆	C1514C	15
	16	20 ⁹ / ₁₆	C1516C	15

17.5 Ton	2	6 ⁷ / ₈	RT172	22
-----------------	---	-------------------------------	--------------	----

20 Ton	7 ¹ / ₁₆	2	RLS200	18
	1 ³ / ₄	3 ³ / ₄	RSS202	19
	2	6 ¹ / ₈	RH202	20
	2 ¹ / ₈	6 ³ / ₈	RA202	17
	3	6 ¹ / ₁₆	RH203	20
	4 ¹ / ₈	8 ³ / ₈	RA204	17
	6	12 ¹ / ₈	RH206	20
	6 ¹ / ₈	10 ³ / ₈	RA206	17

25 Ton	1	5 ¹ / ₂	C251C	15
	2	6 ¹ / ₂	C252C	15
	4	8 ¹ / ₂	C254C	15
	6 ¹ / ₄	10 ³ / ₄	C256C	15
	6 ¹ / ₄	13 ³ / ₈	C256CBT	16
	6 ¹ / ₄	12 ³ / ₈	RD256	25
	8 ¹ / ₄	12 ³ / ₄	C258C	15

25 Ton	10 ¹ / ₄	14 ³ / ₄	C2510C	15
	12 ¹ / ₄	16 ³ / ₄	C2512C	15
	14 ¹ / ₈	18 ³ / ₄	C2514C	15
	14 ¹ / ₈	21 ³ / ₈	C2514CBT	16
	14 ¹ / ₈	20 ³ / ₈	RD2514	25

30 Ton	1 ¹ / ₂	2 ⁵ / ₁₆	RLS300	18
	2 ¹ / ₈	7 ³ / ₈	RA302	17
	2 ⁷ / ₁₆	4 ⁵ / ₈	RSS302	19
	2 ¹ / ₂	6 ¹ / ₄	RH302	20
	2 ¹ / ₂	8 ⁷ / ₁₆	RT302	22
	3	7 ¹ / ₁₆	RH303	21
	4 ¹ / ₈	9 ³ / ₈	RA304	17
	5 ⁷ / ₈	11 ¹ / ₈	RHA306	20
	6	9 ³ / ₄	RH306	20
	6	11 ¹ / ₁₆	RH306D	21
	6 ¹ / ₈	11 ³ / ₈	RA306	17
10 ¹ / ₈	17 ¹ / ₄	RH3010	21	

50 Ton	1 ¹ / ₁₆	2 ⁵ / ₈	RLS500S	18
	2 ³ / ₈	5	RSS502	19
	3	7 ¹ / ₈	RH503	20
	3	10 ⁹ / ₁₆	RT503	22

55 Ton	2	4 ¹⁵ / ₁₆	R552C	26
	2	6 ³ / ₈	R552L	32
	2	6 ⁷ / ₈	C552C	15
	2 ¹ / ₈	6 ³ / ₄	RA552	17
	4 ¹ / ₈	8 ³ / ₄	RA554	17
	4 ¹ / ₄	9 ¹ / ₈	C554C	15
	6	8 ¹⁵ / ₁₆	R556C	26
	6	10 ³ / ₈	R556L	32
	6 ¹ / ₈	10 ³ / ₄	RA556	17
	6 ¹ / ₈	12 ¹ / ₂	RA556L	30
	6 ¹ / ₄	11 ¹ / ₈	C556C	15
	6 ¹ / ₄	12 ³ / ₃₂	RD556	25
	10	12 ¹⁵ / ₁₆	R5510C	26
	10	14 ³ / ₈	R5510L	32
	10	15 ¹ / ₈	RA5510	17
10 ¹ / ₄	15 ¹ / ₈	C5510C	15	
13 ¹ / ₈	19 ²⁷ / ₃₂	RD5513	25	
13 ¹ / ₄	18 ¹ / ₈	C5513C	15	
18 ¹ / ₈	25 ⁷ / ₈	RD5518	25	

60 Ton	3	9 ¹ / ₄	RH603	20
	4	9 ¹ / ₂	RHA604D	21
	5	9 ¹ / ₂	RH605	21
	6	12 ¹ / ₂	RH606	20
	10 ¹ / ₈	18 ¹ / ₁₆	RH6010	21

75 Ton	5 ¹ / ₈	3 ¹ / ₈	RLS750S	18
	6 ¹ / ₈	12 ³ / ₈	C756C	15
	13 ¹ / ₈	19 ³ / ₈	C7513C	15

80 Ton	13 ¹ / ₈	20 ³ / ₈	RD8013	25
---------------	--------------------------------	--------------------------------	---------------	----

100 Ton	5 ¹ / ₈	3 ³ / ₈	RLS1000S	18
	1 ¹ / ₂	5 ¹¹ / ₁₆	RSS1002D	19
	1 ¹ / ₂	6 ¹ / ₂	RH1001	21
	2	5 ¹ / ₂	R1002C	26
	2	6 ⁴¹ / ₆₄	R1002D	28
	2	7 ¹ / ₄	R1002L	32
	2	8 ⁵ / ₈	C1002C	15
	2 ¹ / ₈	7 ³ / ₄	RA1002	17

Re-tracted				Re-tracted			
Stroke (in.)	Height (in.)	Order No.	Page No.	Stroke (in.)	Height (in.)	Order No.	Page No.

100 Ton	2 ¹ / ₄	5 ¹ / ₂	RSS1002	19
	3	10	RH1003	20
	4 ⁷ / ₈	15 ¹ / ₈	RT1004	22
	6	9 ¹ / ₂	R1006C	26
	6	10 ⁴¹ / ₆₄	R1006D	28
	6	11 ¹ / ₄	R1006L	32
	6	12 ³ / ₈	RH1006	21
	6 ¹ / ₄	11 ³ / ₄	RA1006	17
	6 ¹ / ₄	13 ³ / ₈	RA1006L	30
	6 ⁵ / ₈	13 ¹ / ₄	C1006C	15
	6 ⁵ / ₈	13 ²⁵ / ₃₂	RD1006	25
	10	13 ¹ / ₂	R10010C	*
	10	14 ⁴¹ / ₆₄	R10010D	28
	10	15 ¹ / ₄	R10010L	32

150 Ton	9 ¹ / ₁₆	4	RLS1500S	18
	2	6 ³ / ₈	R1502C	26
	2	7 ⁷ / ₁₆	R1502D	28
	2	8 ¹ / ₈	R1502L	32
	5	12 ¹ / ₈	RH1505	21
	6	10 ³ / ₈	R1506C	26
	6	11 ⁷ / ₁₆	R1506D	28
	6	12 ¹ / ₈	R1506L	32
	6 ⁵ / ₈	14 ⁷ / ₈	RD1506	25
	8	13 ³ / ₄	RH1508	21
	10	14 ³ / ₈	R15010C	26
	10	15 ⁷ / ₁₆	R15010D	*
	10	16 ¹ / ₈	R15010L	*
	13 ¹ / ₈	21 ³ / ₈	RD15013	25
	18 ¹ / ₈	26 ¹⁷ / ₃₂	RD15018	25

200 Ton	2	7 ¹ / ₂	R2002C	26
	2	8 ⁹ / ₆₄	R2002D	28
	2	9 ¹ / ₂	R2002L	32
	6	11 ¹ / ₂	R2006C	26
	6	12 ⁹ / ₆₄	R2006D	28
	6	13 ¹ / ₂	R2006L	32
	6 ⁵ / ₈	16	RD2006	25
	8	16 ¹ / ₁₆	RH2008	21
	10	15 ¹ / ₂	R20010C	*
	10	16 ⁹ / ₆₄	R20010D	28
	10	17 ¹ / ₂	R20010L	*
	13 ¹ / ₈	22 ¹ / ₂	RD20013	25
	18 ¹ / ₈	28 ¹ / ₂	RD20018	25

250 Ton	3	11 ⁷ / ₁₆	RSS2503	19
----------------	---	---------------------------------	----------------	----

280 Ton	2	7 ¹ / ₂	R2802C	26
	2	9 ¹³ / ₆₄	R2802D	28
	2	9 ³ / ₄	R2802L	32
	6	11 ¹ / ₂	R2806C	26
	6	13 ¹³ / ₆₄	R2806D	28
	6	13 ³ / ₄	R2806L	32
	10	15 ¹ / ₂	R28010C	*
	10	17 ¹³ / ₆₄	R28010D	28
	10	17 ³ / ₄	R28010L	32

300 Ton	6	17 ⁹ / ₃₂	RD3006	25
	13	24 ⁹ / ₃₂	RD30013	25

355 Ton	2	9 ¹ / ₈	R3552C	26
	2	11 ¹ / ₂	R3552L	28
	2	15 ³ / ₈	R3552D	26
	6	12 ⁵ / ₈	R3556C	28
	6	15 ¹ / ₂	R3556L	32
	6	17 ²¹ / ₃₂	R3556D	28
	10	17 ¹ / ₈	R3	

CYLINDER SELECTION

Choose The Right Cylinder

Step 1 Select the hydraulic cylinder that best suits the application. See page 7, 12-13.

Step 2 Select the hydraulic pump, with valve option, that best matches the cylinder and application. See pages 6, 42-49, 120-121.

Step 3 Select the hydraulic accessories you need. See pages 34-39.

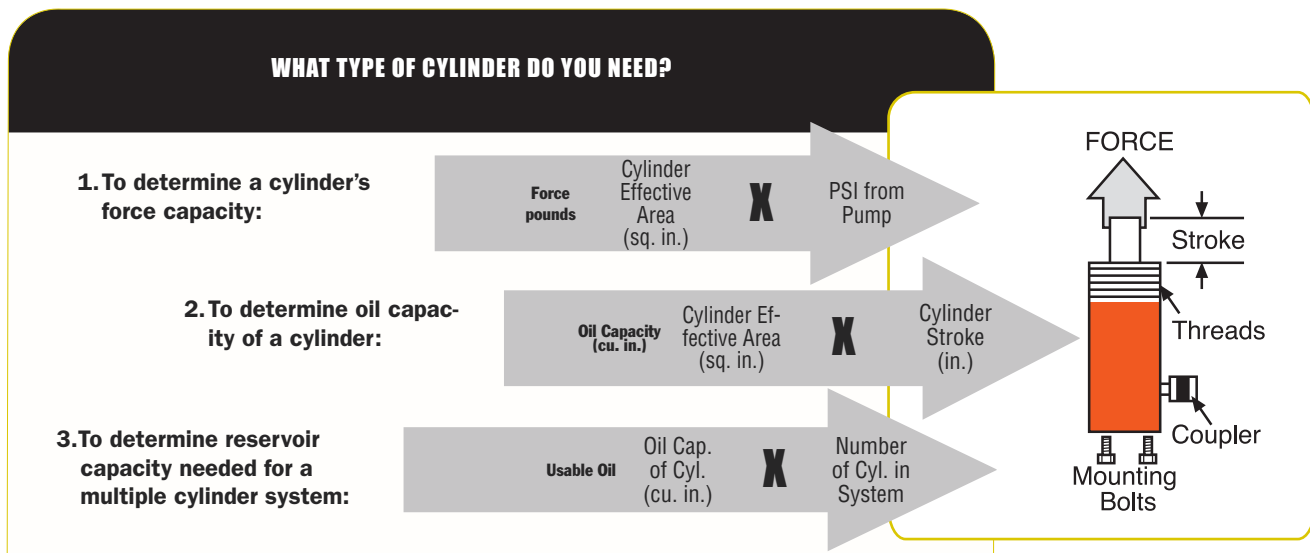

CONSIDERATIONS:

1. What push or pull tonnage is required per cylinder in your application? (Rule of thumb; Always choose a cylinder with a tonnage rating of 20% or more than what is required to lift the load.)
2. What is the push or pull stroke length required?
3. Does the cylinder need to push, pull or both? (Single-acting cylinders extend the piston under hydraulic pressure; double-acting cylinders extend and retract the piston under pressure.)
4. Does the application require multiple cylinders?
5. Is the application stationary, or must the components be light in weight for easy portability?
6. Do you need to extend a rod or cable through the center of the cylinder for the application, as in a tensioning operation?
7. Does the application require that the cylinder fit within limited-clearance work areas?
8. Does the application require that the cylinder be "dead-ended" at the end of its work stroke?
9. Will the cylinder need to withstand off-center loads? Cylinders with swivel caps are available.
10. Does the application require that the lifted load be supported for extended periods of time? Locking-collars are ideal for such jobs, as are cribbing blocks.
11. Is corrosion resistance required? Our unique "Power Tech" surface treatment is standard on many Power Team cylinders, and optional on many of our cylinders which feature steel construction.
12. Will the application involve high cycles (over 2,500 in the cylinders lifetime)? Our "RD", "RH", "RP" and "C" series cylinders are ideal choices. Please refer to pages 12-13 for the capabilities of each cylinder.



ONLY POWER TEAM PROVIDES THE **POWER TECH** SURFACE TREATMENT:

- High corrosion and wear resistance, anti-galling properties.
- Significantly increases the life expectancy of a cylinder.
- Retains lubricants, prevents bronze and other materials from sticking to surface.
- Increases fatigue strength and impact strength.
- Increases surface yield and tensile strength.
- Provides improved abrasion and scratch resistance.
- Causes no appreciable dimensional change.
- 56 Rc minimum surface hardness.
- Passes ASTM B117-85 100 hour salt spray corrosion resistance tests.

The “**Power Tech**” surface treatment is standard on the gland nut, cylinder body and piston/piston rod of the following cylinders: RLS50, RLS100, RLS200, RLS300, RLS500S, RLS750S, RLS1000S, RLS1500S, and RSS1002. NOTE: Bronze plating may be used in place of the “Power Tech” surface finish for the piston/piston rod of any of the above cylinders. The “**Power Tech**” surface treatment is standard on the standpipe of all “RH” series single and double- acting cylinders. The “**Power Tech**” surface treatment is standard on the piston/piston rod of the RT172, RT302 and RT503 cylinders.

HYDRAULIC CIRCUITS

Pumps, Cylinders,
Controls

Countless applications are possible with Power Team hydraulic components. In presses, for lifting or jacking applications or in production or maintenance setups. The pump shown is a typical electric/hydraulic unit. Electric, air or gas driven pumps are available.

1 Single-acting cylinder or cylinders in the circuit, controlled by a pump mounted valve.

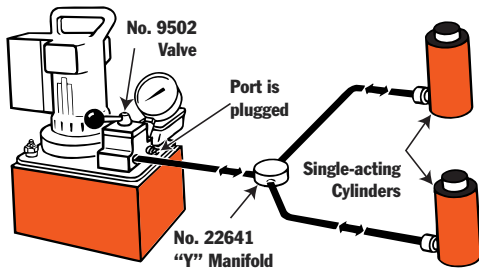

2 Double-acting cylinder or cylinders in the circuit, controlled by a pump mounted valve.

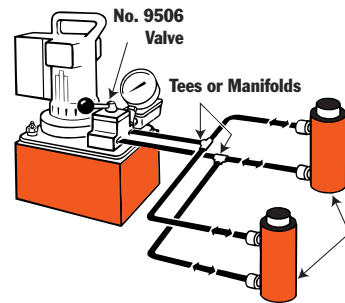

3 Single-acting cylinder controlled by a remote mounted valve.

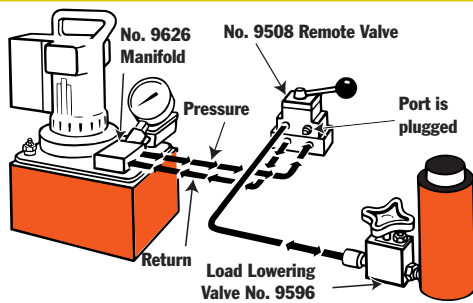

4 Double-acting cylinders controlled by a remote mounted valve.

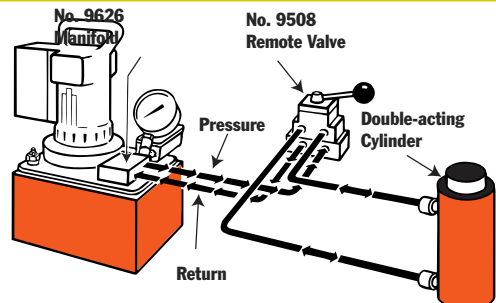

5 Single-acting cylinders with a sequence valve which controls the primary and secondary cylinder circuits.

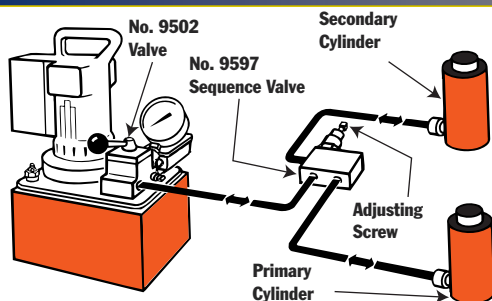

6 Double-acting cylinder with a sequence valve which controls the primary and secondary cylinder circuits.

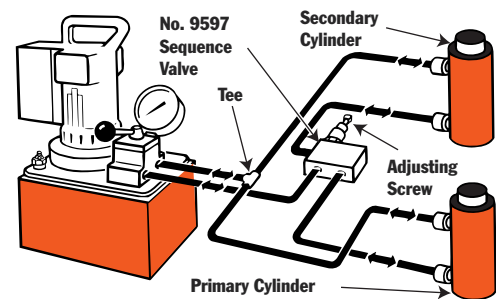

Basic single-acting system with a hand pump, gauge, hose and single-acting cylinder.

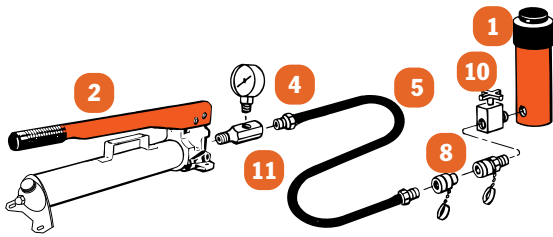

- 1 Cylinder – applies hydraulic force.
- 2 Pump – a device for converting mechanical energy to fluid energy.
- 3 Directional valve – controls the direction of hydraulic fluid in the system.
- 4 Gauge – measures P.S.I. pressure (Pounds per Square Inch) and/ or force.
- 5 Hose – transports hydraulic fluid.
- 6 Manifold – allows distribution of hydraulic fluid from one source to several cylinders. (No. 9617)
- 7 Swivel Connector – allows proper alignment of valves and/or gauges. Used when units being connected cannot be rotated. (No. 10469)

Basic single-acting system with a hand pump, gauge, hose, multiple shut-off valves, load-lowering valves and multiple cylinders.

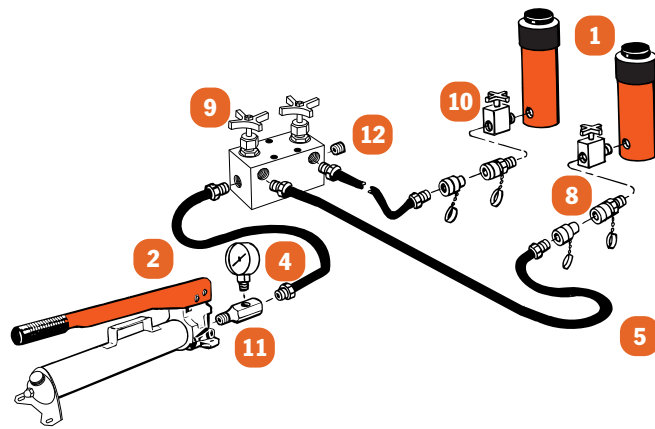

- 8 Quick Coupling – “hose half” and “cylinder half” couplings are used for quick connection and fluid flow check when separated. (No. 9797 and 9798)
- 9 Shut-Off Valve – regulates the flow of hydraulic fluid to or from cylinders. (No. 9642 or 9644)
- 10 Load-Lowering Valve – allows metered lowering of cylinder and provides safety when prolonged load holding is required. (No. 9596)
- 11 Tee Gauge Adapter – allows for installation of pressure/tonnage gauge anywhere in the hydraulic system. (No. 9670)
- 12 Pipe Plug – for blocking unused ports within the system. (No. 10909)

Basic double-acting system with an electric/hydraulic pump, shut-off valves, load-lowering valves and multiple double-acting cylinders.

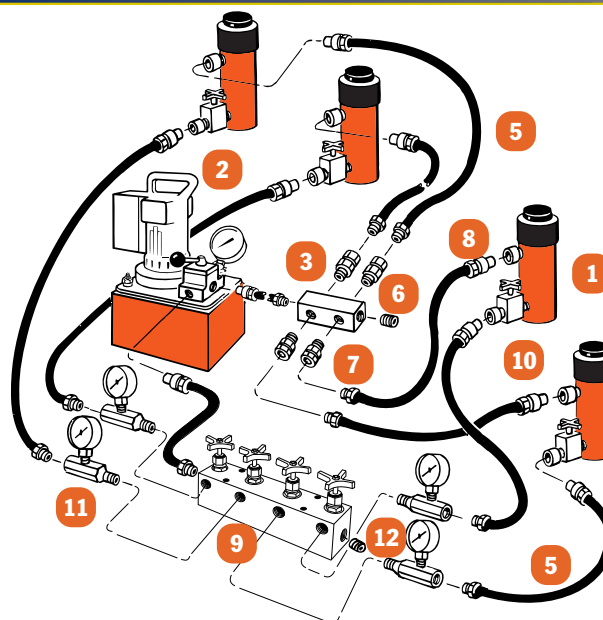

FROM
2
TO
1220
TONS!

CYLINDERS

SUPERIOR FEATURES OF POWER TEAM HYDRAULIC CYLINDERS:

We build our own cylinders in our ISO 9001 registered manufacturing facility. All Power Team cylinders are date-coded. Maximum pressure rating and capacity are stamped on the cylinder. All cylinders comply to the demanding ASME B30.1 standard and are proof tested to 125% of capacity

before leaving our factory. Cylinder bores are roller burnished to harden the surface and make it smoother, increasing seal life by 30%. Base mounting holes withstand full capacity of the cylinder. Typical cylinder burst pressures range from 25,000 to 35,000 psi. Cylinders with gland nuts may be "dead-ended" at 10,000

psi. Cylinders are assembled and tested by certified assemblers. Eddy current and mag particle inspection detects flaws in the steel. Cylinder bodies are solid steel, not welded like some competitive cylinders. Material is removed from surface to assure that any flaws are removed.



Series	Description	Page	Action	TONNAGE									
				2	5	10	12	15	17.5	20	25	30	50
C	General Purpose	14	Single/Spring		X	X		X			X		
CBT	Threaded End Cylinders	16	Single/Spring		X	X					X		
RA	Aluminum Cylinders	17	Single/Spring							X		X	
RD	Industrial Cylinders	18	Double Acting		4	9	16				X		
RLS	Low Profile Cylinders	18	Single/Spring		X	X				X		X	X
RSS	Shorty Cylinders	19	Single/Spring/Double Act			X				X		X	X
RH	Center Hole Cylinders	20	Single/Spring/Double Act			X	X			X		X	X
RT	Center Hole Power Twin Cylinders	22	Single/Spring/Double Act						X			X	X
RP	Pull Cylinders	23	Single/Spring	X	X								
RD	Double Acting Cylinders	24	Double Acting			X					X		
R	High Tonnage Cylinder	26, 28	Single Acting/Load Return/ Double Acting										
RL	Locking Collar Cylinders	30, 32-33	Single Acting/Load Return										
RC	Pancake Cylinders	31	Single Acting/Load Return										

Page
C SERIES... 14
General Purpose Cylinders



Page
CBT SERIES... 16
Threaded End Cylinders



Page
RA SERIES... 17
Aluminum Cylinders



Page
RLS SERIES... 18
Low Profile Cylinders



Page
RSS SERIES... 19
Shorty Cylinders



Page
RH SERIES... 20
Center Hole Cylinders



Page
RT SERIES... 22
Center Hole Power-twin®
Cylinders



Page
RP SERIES... 23
Pull Cylinders



Page
RD SERIES... 24
Double-Acting,
Hydraulic-Return



Page
R SERIES... 26, 28
Single Acting, Load Return
Double-Acting,
Hydraulic Return



Page
RL ALUMINUM ... 30
Locking Collar Aluminum



Page
RC SERIES... 31
Pancake cylinders



Page
RL STEEL... 32
Locking Collar Steel



Page
ACCESSORIES ... 34-39

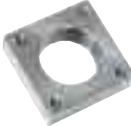

	TONNAGE													740 TO			
	55	60	75	80	100	150	200	250	280	300	355	400	430		500	565	1220
C	X		X		X												
CBT																	
RA	X				X												
RLS			X		X	X											
RSS					X			X									
RH		X			X	X	X										
RT					X												
RP																	
RD	X			X	X	X	X			X		X		X			
R	X				X	X	X		X		X		X		X	X	
RL	X†				X†	X	X		X		X		X		X	X	
RC	X				X	X		240		X					620		

† LOCKING COLLAR AVAILABLE IN ALUMINUM.

GENERAL PURPOSE

6-SERIES

General Purpose, Single Acting,
Spring-Return



CYLINDERS



C106C

RUGGED, HIGH QUALITY CYLINDER USED FOR LIFTING AND PRESSING

- Aluminum bronze bearing reduces wear caused by off-center loads.
- Maximum sized springs speed piston return and increase spring life.
- Solid steel cylinder body for durability.
- Chrome plated piston rod resists wear and corrosion.
- Wide range of accessories available to thread onto piston rod, collar, or onto cylinder base.
- Base mounting holes standard on 5 through 55 ton cylinders; optional on 75 and 100 ton cylinders.
- A 3/8" NPTF female half coupler is standard.

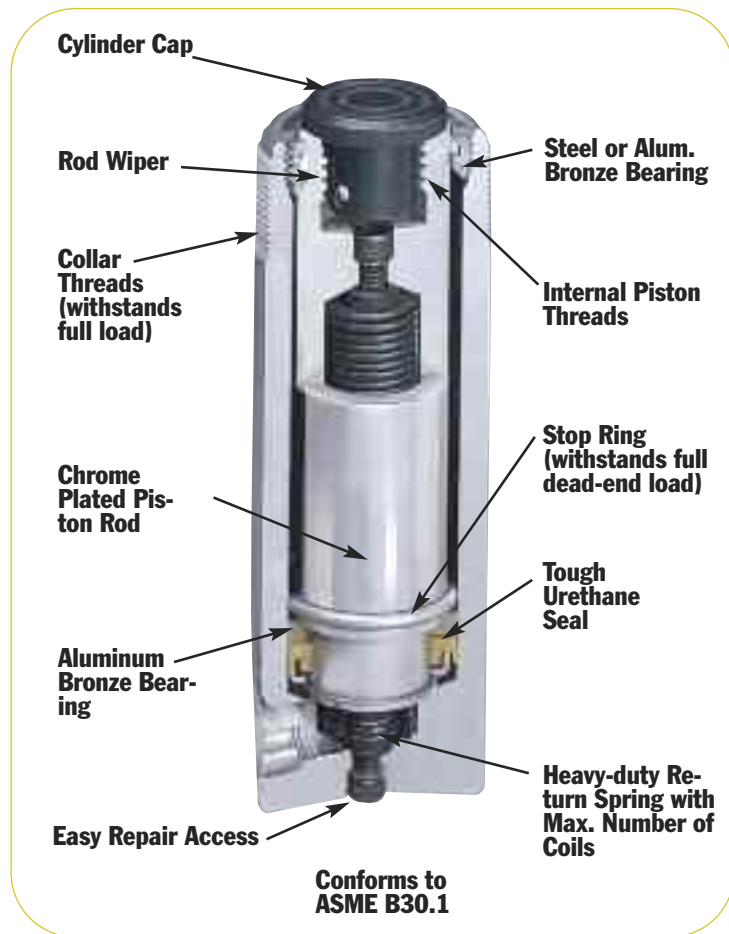

C756C

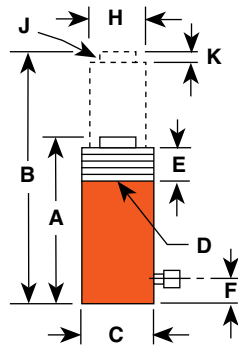

Cyl Cap Tons	Stroke (in.)	Order No.	Oil Cap. (cu. in.)	A	B	C	D	E	F	H	J	K	Bore Dia. (in.)	Cylinder Effective Area (sq. in.)	Internal Press. at Cap. (psi)	Tons at 10,000 (psi)	Prod. Wt. (lbs.)
				Re-tracted Height (in.)	Ex- tended Height (in.)	Outside Dia. (in.)	Collar Thread (in.)	Piston Collar Thread Length (in.)	Base to Port (in.)	Piston Rod Dia. (in.)	Piston Rod Int. Thread and Depth (in.)	Rod Protru- sion (in.)					
5	1	C51C	1.1	4 ¹¹ / ₃₂	5 ⁷ / ₁₆	1 ¹ / ₂	1 ¹ / ₂ -16	1 ¹ / ₈	3 ³ / ₄	1	3 ³ / ₄ -16 x 5 ⁵ / ₈	1 ¹ / ₄	1 ¹ / ₈	.994	10,061	4.97	2.25
	3 ³ / ₄	C53C	3.2	6 ¹ / ₂	9 ³ / ₄	1 ¹ / ₂	1 ¹ / ₂ -16	1 ¹ / ₈	3 ³ / ₄	1	3 ³ / ₄ -16 x 5 ⁵ / ₈	1 ¹ / ₄	1 ¹ / ₈	.994	10,061	4.97	3.26
	5 ¹ / ₄	C55C	5.2	8 ¹ / ₂	13 ³ / ₄	1 ¹ / ₂	1 ¹ / ₂ -16	1 ¹ / ₈	3 ³ / ₄	1	3 ³ / ₄ -16 x 5 ⁵ / ₈	1 ¹ / ₄	1 ¹ / ₈	.994	10,061	4.97	4
	7 ¹ / ₄	C57C	7.2	10 ³ / ₄	18	1 ¹ / ₂	1 ¹ / ₂ -16	1 ¹ / ₈	3 ³ / ₄	1	3 ³ / ₄ -16 x 5 ⁵ / ₈	1 ¹ / ₄	1 ¹ / ₈	.994	10,061	4.97	5
	9 ¹ / ₄	C59C	9.2	12 ³ / ₄	22	1 ¹ / ₂	1 ¹ / ₂ -16	1 ¹ / ₈	3 ³ / ₄	1	3 ³ / ₄ -16 x 5 ⁵ / ₈	1 ¹ / ₄	1 ¹ / ₈	.994	10,061	4.97	5.8
10	1	C101C	2.2	3 ⁵ / ₈	4 ⁵ / ₈	2 ¹ / ₄	2 ¹ / ₄ -14	1 ¹ / ₈	3 ³ / ₄	1 ¹ / ₂	1-8 x 3 ³ / ₄	1 ¹ / ₄	1 ¹¹ / ₁₆	2.236	8,948	11.2	4
	2 ¹ / ₈	C102C	4.8	4 ³ / ₄	6 ⁷ / ₈	2 ¹ / ₄	2 ¹ / ₄ -14	1 ¹ / ₈	3 ³ / ₄	1 ¹ / ₂	1-8 x 3 ³ / ₄	1 ¹ / ₄	1 ¹¹ / ₁₆	2.236	8,948	11.2	5
	4 ¹ / ₈	C104C	9.2	6 ³ / ₄	10 ⁷ / ₈	2 ¹ / ₄	2 ¹ / ₄ -14	1 ¹ / ₈	3 ³ / ₄	1 ¹ / ₂	1-8 x 3 ³ / ₄	1 ¹ / ₄	1 ¹¹ / ₁₆	2.236	8,948	11.2	6.7
	6 ¹ / ₈	C106C	13.7	9 ³ / ₄	15 ⁵ / ₈	2 ¹ / ₄	2 ¹ / ₄ -14	1 ¹ / ₈	3 ³ / ₄	1 ¹ / ₂	1-8 x 3 ³ / ₄	1 ¹ / ₄	1 ¹¹ / ₁₆	2.236	8,948	11.2	9.4
	8 ¹ / ₈	C108C	19.9	11 ³ / ₄	19 ⁷ / ₈	2 ¹ / ₄	2 ¹ / ₄ -14	1 ¹ / ₈	3 ³ / ₄	1 ¹ / ₂	1-8 x 3 ³ / ₄	1 ¹ / ₄	1 ¹¹ / ₁₆	2.236	8,948	11.2	11
	10 ¹ / ₈	C1010C	22.6	13 ³ / ₄	23 ⁷ / ₈	2 ¹ / ₄	2 ¹ / ₄ -14	1 ¹ / ₈	3 ³ / ₄	1 ¹ / ₂	1-8 x 3 ³ / ₄	1 ¹ / ₄	1 ¹¹ / ₁₆	2.236	8,948	11.2	13
	12 ¹ / ₈	C1012C	27.1	15 ³ / ₄	27 ⁷ / ₈	2 ¹ / ₄	2 ¹ / ₄ -14	1 ¹ / ₈	3 ³ / ₄	1 ¹ / ₂	1-8 x 3 ³ / ₄	1 ¹ / ₄	1 ¹¹ / ₁₆	2.236	8,948	11.2	14.6
	14 ¹ / ₈	C1014C	31.6	17 ³ / ₄	31 ⁷ / ₈	2 ¹ / ₄	2 ¹ / ₄ -14	1 ¹ / ₈	3 ³ / ₄	1 ¹ / ₂	1-8 x 3 ³ / ₄	1 ¹ / ₄	1 ¹¹ / ₁₆	2.236	8,948	11.2	16.2
16	C1016C	36.1	20 ¹ / ₂	36 ¹ / ₂	2 ¹ / ₄	2 ¹ / ₄ -14	1 ¹ / ₈	3 ³ / ₄	1 ¹ / ₂	1-8 x 3 ³ / ₄	1 ¹ / ₄	1 ¹¹ / ₁₆	2.236	8,948	11.2	18.5	
15	1	C151C	3.1	4 ⁷ / ₈	5 ⁷ / ₈	2 ³ / ₄	2 ³ / ₄ -16	1 ¹ / ₈	3 ³ / ₄	1 ³ / ₄	1-8 x 3 ³ / ₄	1 ¹ / ₄	2	3.142	9,549	15.7	7.5
	2 ¹ / ₈	C152C	6.7	5 ⁵ / ₈	8	2 ³ / ₄	2 ³ / ₄ -16	1 ¹ / ₈	3 ³ / ₄	1 ³ / ₄	1-8 x 3 ³ / ₄	1 ¹ / ₄	2	3.142	9,549	15.7	8.9
	4 ¹ / ₈	C154C	12.9	7 ⁷ / ₈	12	2 ³ / ₄	2 ³ / ₄ -16	1 ¹ / ₈	3 ³ / ₄	1 ³ / ₄	1-8 x 3 ³ / ₄	1 ¹ / ₄	2	3.142	9,549	15.7	11.5
	6 ¹ / ₈	C156C	19.2	10 ¹¹ / ₁₆	16 ¹³ / ₁₆	2 ³ / ₄	2 ³ / ₄ -16	1 ¹ / ₈	3 ³ / ₄	1 ³ / ₄	1-8 x 3 ³ / ₄	1 ¹ / ₄	2	3.142	9,549	15.7	15.3
	8 ¹ / ₈	C158C	25.5	12 ¹¹ / ₁₆	20 ¹³ / ₁₆	2 ³ / ₄	2 ³ / ₄ -16	1 ¹ / ₈	3 ³ / ₄	1 ³ / ₄	1-8 x 3 ³ / ₄	1 ¹ / ₄	2	3.142	9,549	15.7	17.9
	10 ¹ / ₈	C1510C	31.8	14 ¹¹ / ₁₆	24 ¹³ / ₁₆	2 ³ / ₄	2 ³ / ₄ -16	1 ¹ / ₈	3 ³ / ₄	1 ³ / ₄	1-8 x 3 ³ / ₄	1 ¹ / ₄	2	3.142	9,549	15.7	20.7
	12 ¹ / ₈	C1512C	38.1	16 ¹¹ / ₁₆	28 ¹³ / ₁₆	2 ³ / ₄	2 ³ / ₄ -16	1 ¹ / ₈	3 ³ / ₄	1 ³ / ₄	1-8 x 3 ³ / ₄	1 ¹ / ₄	2	3.142	9,549	15.7	23.2
	14 ¹ / ₈	C1514C	44.4	18 ¹¹ / ₁₆	32 ¹³ / ₁₆	2 ³ / ₄	2 ³ / ₄ -16	1 ¹ / ₈	3 ³ / ₄	1 ³ / ₄	1-8 x 3 ³ / ₄	1 ¹ / ₄	2	3.142	9,549	15.7	26
16	C1516C	50.3	20 ⁹ / ₁₆	36 ⁹ / ₁₆	2 ³ / ₄	2 ³ / ₄ -16	1 ¹ / ₈	3 ³ / ₄	1 ³ / ₄	1-8 x 3 ³ / ₄	1 ¹ / ₄	2	3.142	9,549	15.7	28.2	
25	1	C251C	5.1	5 ¹ / ₂	6 ¹ / ₂	3 ³ / ₈	3 ³ / ₈ -12	1 ¹⁵ / ₁₆	1	2 ¹ / ₄	1 ¹ / ₂ -16 x 7 ⁷ / ₈	3 ³ / ₈	2 ⁹ / ₁₆	5.15	9,699	25.8	11.9
	2	C252C	10.3	6 ¹ / ₂	8 ¹ / ₂	3 ³ / ₈	3 ³ / ₈ -12	1 ¹⁵ / ₁₆	1	2 ¹ / ₄	1 ¹ / ₂ -16 x 7 ⁷ / ₈	3 ³ / ₈	2 ⁹ / ₁₆	5.15	9,699	25.8	13.9
	4	C254C	20.6	8 ¹ / ₂	12 ¹ / ₂	3 ³ / ₈	3 ³ / ₈ -12	1 ¹⁵ / ₁₆	1	2 ¹ / ₄	1 ¹ / ₂ -16 x 7 ⁷ / ₈	3 ³ / ₈	2 ⁹ / ₁₆	5.15	9,699	25.8	17.6
	6 ¹ / ₄	C256C	32.2	10 ³ / ₄	17	3 ³ / ₈	3 ³ / ₈ -12	1 ¹⁵ / ₁₆	1	2 ¹ / ₄	1 ¹ / ₂ -16 x 7 ⁷ / ₈	3 ³ / ₈	2 ⁹ / ₁₆	5.15	9,699	25.8	21.7
	8 ¹ / ₄	C258C	42.5	12 ³ / ₄	21	3 ³ / ₈	3 ³ / ₈ -12	1 ¹⁵ / ₁₆	1	2 ¹ / ₄	1 ¹ / ₂ -16 x 7 ⁷ / ₈	3 ³ / ₈	2 ⁹ / ₁₆	5.15	9,699	25.8	25.6
	10 ¹ / ₄	C2510C	52.8	14 ³ / ₄	25	3 ³ / ₈	3 ³ / ₈ -12	1 ¹⁵ / ₁₆	1	2 ¹ / ₄	1 ¹ / ₂ -16 x 7 ⁷ / ₈	3 ³ / ₈	2 ⁹ / ₁₆	5.15	9,699	25.8	29.3
	12 ¹ / ₄	C2512C	63.2	16 ³ / ₄	29	3 ³ / ₈	3 ³ / ₈ -12	1 ¹⁵ / ₁₆	1	2 ¹ / ₄	1 ¹ / ₂ -16 x 7 ⁷ / ₈	3 ³ / ₈	2 ⁹ / ₁₆	5.15	9,699	25.8	33.1
	14 ¹ / ₄	C2514C	73.5	18 ³ / ₄	33	3 ³ / ₈	3 ³ / ₈ -12	1 ¹⁵ / ₁₆	1	2 ¹ / ₄	1 ¹ / ₂ -16 x 7 ⁷ / ₈	3 ³ / ₈	2 ⁹ / ₁₆	5.15	9,699	25.8	36.8
55	2	C552C	22.1	6 ⁷ / ₈	8 ⁷ / ₈	5	5-12	2 ⁵ / ₁₆	1 ³ / ₈	3 ³ / ₈	None	1 ¹ / ₈	3 ³ / ₄	11.04	9,959	55.2	32.5
	4 ¹ / ₄	C554C	46.9	9 ¹ / ₈	13 ³ / ₈	5	5-12	2 ⁵ / ₁₆	1 ³ / ₈	3 ³ / ₈	None	1 ¹ / ₈	3 ³ / ₄	11.04	9,959	55.2	41.3
	6 ¹ / ₄	C556C	69.0	11 ¹ / ₈	17 ³ / ₈	5	5-12	2 ⁵ / ₁₆	1 ³ / ₈	3 ³ / ₈	None	1 ¹ / ₈	3 ³ / ₄	11.04	9,959	55.2	51
	10 ¹ / ₄	C5510C	113.2	15 ¹ / ₈	25 ³ / ₈	5	5-12	2 ⁵ / ₁₆	1 ³ / ₈	3 ³ / ₈	None	1 ¹ / ₈	3 ³ / ₄	11.04	9,959	55.2	67
	13 ¹ / ₄	C5513C	146.3	18 ³ / ₈	31 ³ / ₈	5	5-12	2 ⁵ / ₁₆	1 ³ / ₈	3 ³ / ₈	None	1 ¹ / ₈	3 ³ / ₄	11.04	9,959	55.2	78
75	6 ¹ / ₈	C756C	97.4	12 ³ / ₈	18 ¹ / ₂	5 ³ / ₄	5 ³ / ₄ -12	1 ¹ / ₄	1 ¹ / ₄	3 ³ / ₄	None	1 ¹ / ₈	4 ¹ / ₂	15.90	9,434	79.5	73.5
	13 ¹ / ₈	C7513C	208.7	19 ³ / ₈	32 ¹ / ₂	5 ³ / ₄	5 ³ / ₄ -12	1 ¹ / ₄	1 ¹ / ₄	3 ³ / ₄	None	1 ¹ / ₈	4 ¹ / ₂	15.90	9,434	79.5	109.5
	2	C1002C	41.2	8 ³ / ₈	10 ³ / ₈	6 ¹ / ₄	6 ¹ / ₄ -12	2 ¹ / ₄	1 ⁵ / ₈	4 ¹ / ₈	None	1 ¹ / ₈	5 ¹ / ₈	20.62	9,695	103.1	63
	6 ¹ / ₈	C1006C	137.0	13 ³ / ₄	19 ³ / ₈	6 ¹ / ₄	6 ¹ / ₄ -12	2 ¹ / ₄	1 ⁵ / ₈	4 ¹ / ₈	None	1 ¹ / ₈	5 ¹ / ₈	20.62	9,695	103.1	91
100	10 ¹ / ₄	C10010C	211.5	16 ³ / ₈	27 ³ / ₈	6 ¹ / ₄	6 ¹ / ₄ -12	2 ¹ / ₄	1 ⁵ / ₈	4 ¹ / ₈	None	1 ¹ / ₈	5 ¹ / ₈	20.62	9,695	103.1	113

THREADED END

CBT Series

5-25 TONS Single Acting,
Spring-Return



CYLINDERS

THREADED PISTON ROD END AND BASE THREADS ACCOMMODATE ACCESSORIES AND ADAPTERS.

- Threaded cylinder collars, piston rod ends, and internal base threads simplify mounting.
- A 9796 3/8" NPTF female half coupler is standard with each cylinder; oil port threads are 3/8" NPTF.

ASME B30.1
10,000 PSI



C55CBT



C2514CBT

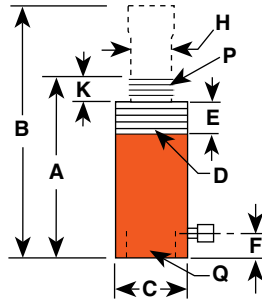

Cyl. Cap. (tons)	Stroke (in.)	Order No.	Oil Cap. (cu. in.)	A	B	C	D	E	F	H	K	P	Q	Bore Dia. (in.)	Cyl. Eff. Area (sq. in.)	Internal Press. at Cap. (psi)	Tons at 10,000 (psi)	Prod. Wt. (lbs.)
				Re-tracted Height (in.)	Ex-tended Height (in.)	Outside Dia. (in.)	Collar Thread (in.)	Collar Thread Length (in.)	Base to Port (in.)	Piston Rod Dia. (in.)	Piston Rod Protrusion (in.)	Piston Rod Thread* (NPT)	Internal Base Thread (NPSM) (in.)					
5	5 ¹ / ₄	C55CBT	5.2	10 ¹ / ₂	15 ³ / ₄	1 ¹ / ₂	1 ¹ / ₂ -16	1 ¹ / ₈	1 ⁷ / ₈	1	1 ¹ / ₈	3/4-14	3/4-14	1 ¹ / ₈	.994	10,061	4.97	4.4
10	6 ¹ / ₈	C106CBT	13.9	11 ¹ / ₂	17 ⁵ / ₈	2 ¹ / ₄	2 ¹ / ₄ -14	1 ¹ / ₈	1 ¹¹ / ₁₆	1 ¹ / ₂	1 ¹ / ₁₆	1 ¹ / ₄ -11 ¹ / ₂	1 ¹ / ₄ -11 ¹ / ₂	1 ¹¹ / ₁₆	2.236	8,948	11.2	10.3
	10 ¹ / ₈	C1010CBT	22.9	15 ¹ / ₂	25 ⁵ / ₈	2 ¹ / ₄	2 ¹ / ₄ -14	1 ¹ / ₈	1 ¹¹ / ₁₆	1 ¹ / ₂	1 ¹ / ₁₆	1 ¹ / ₄ -11 ¹ / ₂	1 ¹ / ₄ -11 ¹ / ₂	1 ¹¹ / ₁₆	2.236	8,948	11.2	13.9
25	6 ¹ / ₄	C256CBT	32.2	13 ³ / ₈	19 ⁵ / ₈	3 ³ / ₈	3 ⁵ / ₁₆ -12	1 ¹⁵ / ₁₆	1 ⁷ / ₈	2 ¹ / ₄	1 ⁷ / ₈	2-11 ¹ / ₂	2-11 ¹ / ₂	2 ⁹ / ₁₆	5.157	9,699	25.8	24.6
	14 ¹ / ₄	C2514CBT	73.5	21 ³ / ₈	35 ⁵ / ₈	3 ³ / ₈	3 ⁵ / ₁₆ -12	1 ¹⁵ / ₁₆	1 ⁷ / ₈	2 ¹ / ₄	1 ⁷ / ₈	2-11 ¹ / ₂	2-11 ¹ / ₂	2 ⁹ / ₁₆	5.157	9,699	25.8	40.2

ALUMINUM

RA-SERIES

20-200 TONS

Single Acting, Spring-Return

HALF THE WEIGHT OF EQUAL CAPACITY STEEL CYLINDERS.

- Aluminum body resists sparking in explosive environments.
- Hard coated aluminum piston rod and cylinder bore resist wear and corrosion.
- Grooved piston top helps keep the load from sliding on top of piston.
- Designed for jacking and other non- production operations.



ASME B30.1
10,000 PSI



CYLINDERS

RA552



RA1006

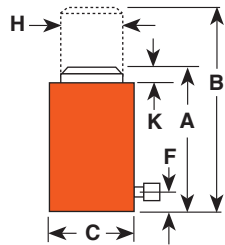

Base Mtg. Holes (4) at 45° from coupler (RA556, RA5510)
3/8"-16 x 4 1/2" Dia. B.C.

Cyl. Cap. (tons)	Order No.	Oil Cap. (cu. in.)	A Retracted Ht. (in.)	B Extended Ht. (in.)	C Outside Dia. (in.)	F Base to Port (in.)	H Piston Rod Dia. (in.)	K Piston Rod Protrusion (in.)	Bore Dia. (in.)	Cylinder Effective Area (sq. in.)	Internal Pressure at Cap. (psi)	Tons at 10,000 psi	Product Wt. (lbs.)
20	2 1/8 RA202	9.41	6 3/8	8 1/2	3 3/4	1 1/4	2	5/16	2 3/8	4.43	9,030	22.15	7.7
	4 1/8 RA204	18.27	8 3/8	12 1/2	3 3/4	1 1/4	2	5/16	2 3/8	4.43	9,030	22.15	9.3
	6 1/8 RA206	27.13	10 3/8	16 1/2	3 3/4	1 1/4	2	5/16	2 3/8	4.43	9,030	22.15	11.3
30	2 1/8 RA302	13.79	7 3/8	9 1/2	4 1/4	1 1/4	2 1/2	3/8	2 7/8	6.49	9,250	32.45	11.1
	4 1/8 RA304	26.77	9 3/8	13 1/2	4 1/4	1 1/4	2 1/2	3/8	2 7/8	6.49	9,250	32.45	13.1
	6 1/8 RA306	39.75	11 3/8	17 1/2	4 1/4	1 1/4	2 1/2	3/8	2 7/8	6.49	9,250	32.45	15.1
55	2 1/8 RA552	23.50	6 3/4	8 7/8	5 1/4	1 3/8	3 1/8	1/4	3 3/4	11.04	9,960	55.2	16.2
	4 1/8 RA554	45.50	8 3/4	12 7/8	5 1/4	1 3/8	3 1/8	1/4	3 3/4	11.04	9,960	55.2	19.6
	6 1/8 RA556*	67.60	10 3/4	16 7/8	5 1/4	1 3/8	3 1/8	1/4	3 3/4	11.04	9,960	55.2	24.0
100	10 RA5510*	110.40	15 1/8	25 1/8	5 1/4	1 3/8	3 1/8	1/4	3 3/4	11.04	9,960	55.2	31.8
	2 1/8 RA1002	43.80	7 3/4	9 7/8	7 3/8	1 3/16	4 1/8	1/8	5 1/8	20.62	9,696	103.1	33.4
	6 1/4 RA1006*	129.00	11 3/4	18	7 3/8	1 3/16	4 1/8	1/8	5 1/8	20.62	9,696	103.1	49.9

* Equipped with carrying handles.

LOW PROFILE

RLS Series

5-150 Ton

Single-Acting, Spring-Return



CYLINDERS



IDEAL FOR CONFINED AREAS FROM 1⁵/₈" TO 4" CLEARANCE.

- Cylinder body, piston and gland nut "Power Tech" treated for corrosion and abrasion resistance (see page 8).
- Standard domed piston rod (5-30 ton) or swivel cap (50-150 ton) minimize effects of off-center loading.
- Unique heavy duty spring provides fast piston return.
- A 9796 3³/₈" NPTF female half coupler is standard with each cylinder (the RLS50 has a 3³/₈" coupler which is not angled). Oil ports are 3³/₈" NPTF.
- Couplers on all cylinders, except RLS50, are angled upward for extra clearance.



RLS100



RLS1000S

ASME B30.1
10,000 PSI

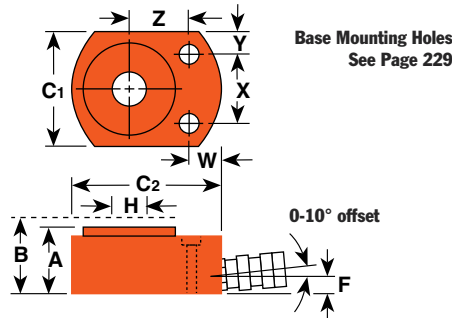

Cyl. Cap. (tons)	Stroke (in.)	Order No.	Oil Cap. (cu. in.)	A	B	C1 & C2	F	H	W	X	Y	Z	Bore Dia. (in.)	Cyl. Area (sq. in.)	Eff. at Cap. (psi)	Int. Press. (psi)	Tons at 10,000 psi	Prod. Wt. (lbs.)
				Re-tracted Height (in.)	Ex-tended Height (in.)	Outside Dia. (in.)	Base to Port (in.)	Piston Rod Dia. (in.)	Mounting Hole Location (in.)									
5	9 ⁹ / ₁₆	RLS50	.62	1 ⁵ / ₈	2 ³ / ₁₆	1 ⁵ / ₈ X 2 ⁹ / ₁₆	3 ³ / ₄	5 ⁵ / ₈	3 ³ / ₄	1 ¹ / ₈	1 ¹ / ₄	1	1 ¹ / ₈	.994	10,061	4.97	2.2	
10	7 ⁷ / ₁₆	RLS100	1.0	1 ³ / ₄	2 ³ / ₁₆	2 ³ / ₁₆ X 3 ¹ / ₄	5 ⁵ / ₈	3 ³ / ₄	1 ¹¹ / ₁₆	1 ⁷ / ₁₆	3 ³ / ₈	1 ⁵ / ₁₆	1 ¹¹ / ₁₆	2.236	8,943	11.18	3.3	
20	7 ⁷ / ₁₆	RLS200	2.0	2	2 ⁷ / ₁₆	3 X 4	2 ¹ / ₃₂	1 ¹ / ₈	2 ²³ / ₃₂	1 ¹⁵ / ₁₆	1 ⁷ / ₃₂	1 ⁹ / ₁₆	2 ³ / ₈	4.430	9,029	22.15	5.6	
30	1 ¹ / ₂	RLS300	3.2	2 ⁵ / ₁₆	2 ¹³ / ₁₆	3 ³ / ₄ X 4 ¹ / ₂	2 ²³ / ₃₂	1 ³ / ₈	1 ¹³ / ₁₆	2 ¹ / ₁₆	2 ⁷ / ₃₂	1 ³ / ₄	2 ⁷ / ₈	6.492	9,242	32.46	8.6	
50	5 ⁵ / ₈	RLS500S	6.0	2 ⁵ / ₈	3 ¹ / ₄	4 ¹ / ₂ X 5 ¹ / ₂	2 ²⁷ / ₃₂	1 ³ / ₄	1 ¹⁵ / ₁₆	2 ⁵ / ₈	1 ¹⁵ / ₁₆	2 ¹ / ₈	3 ¹ / ₂	9.621	10,394	48.10	14.0	
75	5 ⁵ / ₈	RLS750S	9.9	3 ¹ / ₈	3 ³ / ₄	5 ¹⁷ / ₃₂ X 6 ¹ / ₂	1	2 ¹ / ₈	1 ¹⁵ / ₁₆	3	1 ¹⁷ / ₆₄	2 ¹⁹ / ₃₂	4 ¹ / ₂	15.904	9,431	79.52	23.3	
100	5 ⁵ / ₈	RLS1000S	12.3	3 ³ / ₈	4	6 X 7	1	2 ¹ / ₂	1 ¹³ / ₁₆	3	1 ¹ / ₂	2 ¹³ / ₁₆	5	19.635	10,186	98.17	30.0	
150	9 ⁹ / ₁₆	RLS1500S	17.2	4	4 ⁹ / ₁₆	7 ¹ / ₂ X 8 ¹ / ₂	1 ⁵ / ₁₆	3	1 ⁵ / ₁₆	4 ⁵ / ₈	1 ⁷ / ₁₆	3 ¹ / ₈	6 ¹ / ₄	30.680	9,778	153.39	52.0	

**IDEAL FOR CONFINED AREAS
FROM 3 1/2" TO 11 7/16" CLEAR-
ANCE.**

- Power Tech plated piston rods and gland nuts resist scoring and corrosion.
- Heavy duty return spring (except for double-acting models) provides fast piston return & low collapsed height.
- Coupler on 10 thru 50 ton models is angled upward 5° for added clearance.
- Grooved piston top keeps load from sliding.
- Cylinders can be “dead-ended” at full capacity.
- Removable carrying handles on 100 ton and 250 ton models.



RSS2503



Cribbing blocks are shown in a 30 ton RSS302 “Shorty” cylinder. For more information see pg 38.

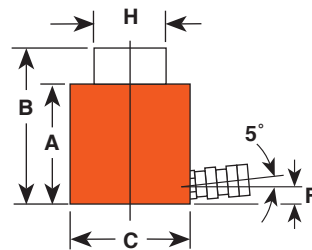

RSS302

ASME B30.1
10,000 PSI



CYLINDERS

Cyl Capacity (Tons)	Stroke (in.)	Order No.	Oil Cap. (cu. in.)		A Retracted Height (in.)	B Extended Height (in.)	C Outside Dia. (in.)	F Base to Port (in.)	H Piston Rod Dia. (in.)	Bore Dia. (in.)	Cylinder Effective Area (sq. in.)	Internal Press. at Cap. (psi)	Tons at 10,000 psi	Prod. Wt. (lbs.)
			Push	Return										
10	1 1/2	RSS101	3.4	-	3 1/2	5	2 3/4	5/8	1 1/2	1 11/16	2.24	8,943	11.2	6.0
20	1 3/4	RSS202	7.7	-	3 3/4	5 1/2	3 9/16	5/8	2 5/32	2 3/8	4.43	9,029	22.1	9.9
30	2 7/16	RSS302	15.8	-	4 5/8	7 1/16	4	5/8	2 1/2	2 7/8	6.49	9,243	32.5	14.7
50	2 3/8	RSS502	22.8	-	5	7 3/8	4 7/8	3/4	3 1/8	3 1/2	9.62	10,393	48.1	23.2
100	2 1/4	RSS1002	44.2	-	5 1/2	7 3/4	6 5/8	15/16	4 3/8	5	19.63	10,186	98.2	47.3
100	1 1/2	RSS1002D	29.4	12.9	5 11/16	7 3/16	6 7/8	15/16*	3 3/4	5	19.63	10,186	98.2	54.6
250	3	RSS2503	150.6	-	11 7/16	14 7/16	9 7/8	1 13/16	5 1/2	8	50.22	9,956	251.1	220.0

*Cylinder top to port is 1 9/16

See pages 28-33 & 124-133 for hydraulic accessories.



CENTER HOLE

RH Series

10-100 Ton

Single-Acting, Spring-Return



CYLINDERS



ASME B30.1
10,000 PSI

10, 20, 100 Ton
Single-Acting Models
Feature Plain Collar

IDEAL FOR PULLING AND TENSIONING OF CABLES, ANCHOR BOLTS, FORCING SCREWS, ETC.

- Interchangeable piston head inserts (see page 39) provide versatility of application.
 - 12, 20*, 30*, 50, 60 Ton Single-Acting Models Feature Threaded Collar
 - Withstands full "dead-end" loads.
 - Corrosion resistant standpipe has "Power Tech" treatment.
 - All cylinders except RH120 are furnished with a 9796 3/8" NPT female half coupler.
 - Aluminum cylinder body and piston are featured on the RHA306 cylinder.
- * Model RH203 and RHA306 do not feature the collar thread. See the chart below.

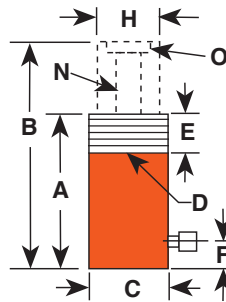

Cyl. Cap. (tons)	Stroke (in.)	Order No.	Oil Cap. (cu. in.)	A Re-tracted Height (in.)	B Ex-tended Height (in.)	C Outside Dia. (in.)	D Collar Thread (in.)	E Collar Thread Length (in.)	F Base to Port (in.)	H Piston Rod Dia. (in.)	N Center Hole Dia. (in.)	O Insert and Size (in.)	Mounting Holes Bolt Circle (in.)	Cylinder Effective Area (sq. in.)	Internal Press. at Cap. (psi)	Tons at 10,000 psi	Prod. Wt. (lbs.)
10	2 1/2	RH102	5.52	5 5/16	7 13/16	3	None	None	1	2 1/16	49/64	1 3/4-12	1/4-20 x 2 3/8	2.21	9,054	11	9
10	8	RH108	17.68	11 5/16	19 5/16	3	None	None	1	2 1/16	49/64	1 3/4-12	1/4-20 x 2 3/8	2.21	9,054	11	18.7
12	5/16	RH120**	.87	2 3/16	2 1/2	2 3/4	2 3/4-16	1 1/4	3/8	1 3/8	11/16	3/4-16	5/16-18 x 2	2.76	8,692	13.8	3
12	1 5/8	RH121	4.49	4 13/16	6 7/16	2 3/4	2 3/4-16	1 1/4	1	1 3/8	51/64	None	None	2.76	8,692	13.8	6.6
12	1 5/8	RH121T**	4.49	4 13/16	6 7/16	2 3/4	2 3/4-16	1 1/4	1	1 3/8	13/16	3/4-16	None	2.76	8,692	13.8	6.6
12	3	RH123	8.29	7 1/4	10 1/4	2 3/4	2 3/4-16	1 3/16	1	1 3/8	13/16	None	None	2.76	8,692	13.8	8.9
20	2	RH202	9.45	6 1/8	8 1/8	3 7/8	3 7/8-12	1 1/2	1	2 1/8	15/64	1 9/16-16	3/8-16 x 3 1/4	4.72	8,466	23.6	16.1
20	3	RH203	11.76	6 1/16	9 1/16	4	None	None	1	2 3/4	13/64	2 1/4-12	3/8-16 x 3 1/4	3.92	10,186	19.6	20
20	6	RH206	28.35	12 1/8	18 1/8	3 7/8	3 7/8-12	1 1/2	1	2 1/8	15/64	1 9/16-16	3/8-16 x 3 1/4	4.72	8,466	23.6	30.2
30	2 1/2	RH302	15.85	6 1/4	8 3/4	4 3/4	4 3/4-12	1 1/2	1 5/32	3 1/4	1 19/64	2 3/4-12	7/16-20 x 3 5/8	6.34	9,457	31.7	25.6
30	5 7/8	RHA306	38.1	11 5/32	17 1/32	5 1/8	None	None	1 1/4	3 1/4	1 9/32	2 5/8-8	None	6.34	9,457	31.7	21.9
30	6	RH306	38.1	9 3/4	15 3/4	4 3/4	4 3/4-12	1 1/2	1 5/32	3 1/4	1 9/32	2 3/4-12	7/16-20 x 3 5/8	6.34	9,457	31.7	39
50	3	RH503	32.58	7 1/8	10 1/8	6	6-12	2	1 1/4	4 1/8	1 43/64	3 1/4-12	5/8-18 x 4 3/4	10.86	9,208	54.3	46.6
60	3	RH603*	37	9 1/4	12 1/4	6 1/4	6 1/4-12	2 1/2	1	3 19/32	2 1/8	3-12	1 1/2-13 x 5 1/8	12.31	9,750	61.6	60
60	6	RH606*	73.86	12 1/4	18 1/4	6 1/4	6 1/4-12	2 1/2	1	3 19/32	2 1/8	3-12	1 1/2-13 x 5 1/8	12.31	9,750	61.6	78
100	3	RH1003*	61.8	10	13	8 3/8	None	None	1 1/4	5	3 1/8	4 1/8-12	None	20.62	9,700	103.1	115

*Supplied with carrying handles.

Aluminum

** RH120 and RH121T do not have an internal threaded insert, but do have a 3/4-16 internal thread. The RH120 inlet port is 1/4" NPTF.

CENTER HOLE

RH Series

30-200 Ton

Double-Acting,

FOR PULLING AND TENSIONING OF CABLES, ANCHOR BOLTS, FORCING SCREWS.

- Interchangeable piston head inserts (see page 39) provide versatility of application.
- Built-in safety feature prevents over-pressurization of the retract circuit.
- Plated piston rod resists wear; superior packings provide high cycle life without leakage.
- Corrosion-resistant standpipe has "Power Tech" treatment (see page 8).
- Each cylinder has 9796 3/8" NPTF female half couplers. The 60 ton thru 200 ton steel models are equipped with removable carrying handles.



ASME B30.1
10,000 PSI

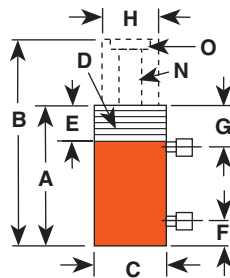

30, 60, 100 Ton
Double-Acting Models Feature
Threaded Collar

Cyl. Cap. (tons)	Stroke (in.)	Order No.	Oil Cap. (cu.in.)		A (in.)	B (in.)	C (in.)	D (in.)	E (in.)	F (in.)	G (in.)	H (in.)	N (in.)	O (in.)	Mounting Holes and Bolt Circle (in.)	Cylinder Effective Area (sq.in.)		Internal Pressure at Cap. (psi)		Tons at 10,000 psi (in.)		Prod. Wt (lbs.)	
			Push	Pull												Push	Pull	Push	Pull	Push	Pull		
30	15	3	RH303	17.6	10.2	7 ¹ / ₁₆	10 ¹ / ₁₆	4 ³ / ₄	None	None	1	1 ⁵ / ₈	2 ¹ / ₂	1 ⁹ / ₃₂	2-12	3 ³ / ₈ -16x3 ⁵ / ₈	5.89	3.38	10,200	8,876	29.5	16.9	29.8
30	15	6	RH306D	35.34	20.28	11 ¹ / ₁₆	17 ¹ / ₁₆	4 ³ / ₄	None	None	1	1 ⁵ / ₈	2 ¹ / ₂	1 ¹⁷ / ₆₄	2-12	7 ¹ / ₁₆ -20x3 ⁵ / ₈	5.89	3.38	10,200	8,876	29.5	16.9	45
30	20	10 ¹ / ₈	RH3010	66	41	17 ¹ / ₄	27 ³ / ₈	4 ¹ / ₂	4 ¹ / ₂ -12	1 ⁵ / ₈	1 ³ / ₄	3 ³ / ₁₆	2 ³ / ₈	1 ⁵ / ₁₆	1 ⁷ / ₈ -16	None	6.54	4.04	9,174	9,901	32.7	20.2	61
60	25	4	RH604D	49.2	20.6	9 ¹ / ₂	13 ¹ / ₂	7	None	None	1 ⁹ / ₁₆	2 ¹ / ₄	4	2 ¹ / ₈	3-12	1 ¹ / ₂ -13x5 ¹ / ₈	12.31	5.15	9,750	9,709	61.5	27.7	35.6
60	25	5	RH605*	61.55	25.77	9 ¹ / ₂	14 ¹ / ₂	6 ¹ / ₃₂	None	None	1	1 ³ / ₄	4	2 ¹ / ₈	3-12	1 ¹ / ₂ -13x5 ¹ / ₈	12.31	5.15	9,750	9,709	61.5	27.7	73
60	40	10 ¹ / ₈	RH6010*	133	87	18 ¹ / ₁₆	28 ³ / ₁₆	6 ¹ / ₄	6 ¹ / ₄ -12	1 ⁷ / ₈	2 ¹ / ₈	3 ⁷ / ₃₂	3 ⁵ / ₈	2 ¹ / ₈	3-16	None	13.14	8.59	9,132	9,313	65.7	42.9	120
100	45	1 ¹ / ₂	RH1001	32.1	14.2	6 ¹ / ₂	8	8 ³ / ₈	None	None	1 ¹ / ₄	2 ⁵ / ₁₆	5	3 ⁹ / ₆₄	4-16	5 ⁵ / ₈ -11x7	21.39	9.43	9,350	9,544	106.9	47.1	85
100	50	6	RH1006*	120.26	5.6	12 ³ / ₈	18 ³ / ₈	7 ¹ / ₄	None	None	1 ¹⁵ / ₃₂	2 ²¹ / ₆₄	4 ³ / ₈	2 ¹ / ₁₆	None	1 ¹ / ₂ -13x5 ¹ / ₂	20.03	10.93	9,986	9,150	100.1	54.7	95
100	45	8	RH10010*	216.6	95.5	19 ¹ / ₂	29 ⁵ / ₈	8 ¹ / ₂	8 ¹ / ₂ -12	2 ¹ / ₄	2 ¹ / ₂	3 ³⁹ / ₆₄	5 ¹ / ₂	3 ⁹ / ₆₄	4 ¹ / ₂ -12	None	21.39	9.43	9,350	9,544	106.9	47.1	240
150	70	5	RH1505*	150.9	73.6	12 ² / ₄ †	17 ¹ / ₄	8 ¹ / ₂	None	None	1 ¹⁵ / ₃₂	2 ¹¹ / ₁₆	5 ¹ / ₂	2 ⁹ / ₁₆	None	None	30.1	14.7	9,937	9,524	150.9	73.6	148
150	75	8	RH1508*	239.6	127.2	13 ³ / ₄	21 ³ / ₄	9 ³ / ₄	None	None	1 ³⁵ / ₆₄	2 ¹³ / ₃₂	6	3 ⁵ / ₃₂	5-12	None	29.95	15.9	10,015	9,434	149.8	79.5	227
200	75	8	RH2008*	323.6	127.6	16 ¹ / ₁₆	24 ¹ / ₁₆	10 ³ / ₄	None	None	2 ¹ / ₄	3 ⁷ / ₃₂	7 ¹ / ₂	4 ¹ / ₁₆	6-12	1 ¹ / ₄ -7 x 7 ³ / ₄	40.45	15.95	9,888	9,404	202.3	79.8	311

* Supplied with carrying handles.

† Measured with 3/4" high serrated insert installed.

See pages 34-39 & 104-133 for hydraulic accessories.

Aluminum

CENTER HOLE

RT Series

17¹/₂-100 Ton

Single- Acting, Spring-
Return & Double-Acting



CYLINDERS



RT 302

ASME B30.1
10,000 PSI

IDEAL FOR PULLING AND PRESS- ING.

- A proven design; used throughout industry for over 45 years.
- Cylinders withstand full “dead-end” loads.
- Compact design; ideal for applications in which space is limited.
- Basic head can be changed from a tapped hole to plain hole by simply changing insert. (See page 39)
- Pistons have “Power Tech” treatment for corrosion and abrasion resistance.

Dimensions for reference only. Single-Acting, Spring-Return Cylinders

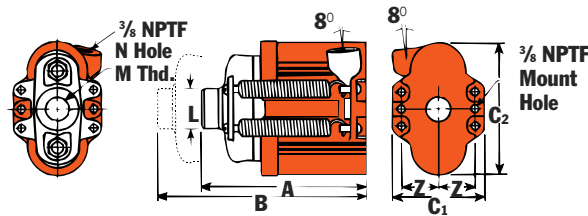

Double-Acting Cylinder (RT1004)

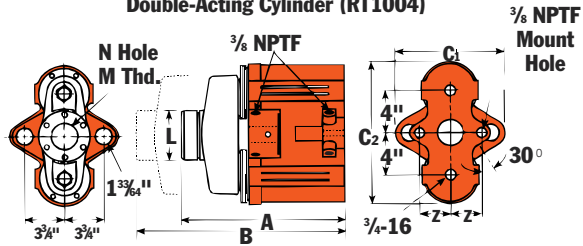

RT 1004

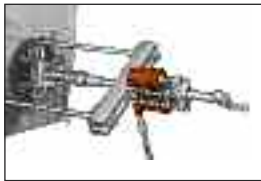

Cyl. Capacity (Tons)	Stroke (in.)	Order No.	Oil Cap. (cu.in.)		A Re- tracted Height (in.)	B Ex- tended Height (in.)	C1 Out- side Dia. (in.)	C2 Out- side Dia. (in.)	L Load Cap Dia. (in.)	M Load Cap Thread (in.)	N Center Hole Dia. (in.)	Z Mounting Hole Location (in.)	Cyl. Mounting Hole (in.)	Int. Press at Cap. (psi)	Tons at 10,000 psl	Prod Wt. (lbs.)	
			Push	Return													
17 1/2	2	RT172	7.06	-	6 ⁷ / ₈	8 ⁷ / ₈	3 ³ / ₄	5 ³ / ₄	1 ³ / ₄	1"-8	1 ¹ / ₃₂	1 ¹ / ₂	1 ¹¹ / ₃₂	3.53	9,915	17.7	14.6
30	2 ¹ / ₂	RT302	15.7	-	8 ⁷ / ₁₆	10 ¹⁵ / ₁₆	4 ¹ / ₄	7 ¹ / ₂	2 ¹ / ₄	1 ¹ / ₄ "-7	1 ¹⁹ / ₆₄	1 ¹³ / ₁₆	1 ¹⁵ / ₃₂	6.28	9,554	31.4	28.2
50	3	RT503	29.4	-	10 ⁹ / ₁₆	13 ⁹ / ₁₆	5 ⁷ / ₈	9 ³ / ₈	2 ⁷ / ₈	1 ⁵ / ₈ "-5 ¹ / ₂	1 ⁴³ / ₆₄	2 ³ / ₈	2 ¹ / ₃₂	9.81	10,193	49.1	56.0
100	4 ⁷ / ₈ **	RT1004	96.5	63.2	15 ¹ / ₈	20	10 ¹ / ₂	13 ¹ / ₄	4 ³ / ₄	2 ¹ / ₂ "-8	2 ⁹ / ₁₆	2 ⁷ / ₈	2 ⁵ / ₃₂	19.24*	10,395	96.2	160

** The RT1004 has a bypass when full stroke is reached, preventing over-pressurization of the cylinder.

NOTE: Each cylinder complete with threaded cylinder head insert, cylinder half coupler and cylinder attaching screws.

PULLING

RP Series

2 & 5 Ton

Single-Acting, Spring-Return



CYLINDERS



RP55

DESIGNED FOR PULLING AND TENSIONING.

- Heavy duty compression spring provides long cycle life and rapid extension of piston.
- Spring automatically extends piston rod when pump pressure is released.

ASME B30.1
10,000 PSI



RP25

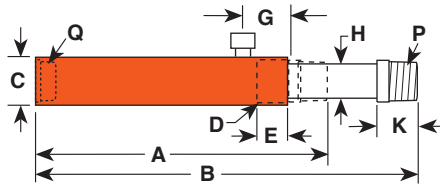

Cyl. Cap. (Tons)	Stroke (in.)	Order No.	Oil Cap. (cu. in.)	A Re-tracted Height (in.)	B Ex-tended Height (in.)	C Outside Dia. (in.)	D Collar Thread (in.)	E Collar Thread Length (in.)	G Cylinder Top to Port (in.)	H Piston Rod Dia. (in.)	K Piston Rod Protrusion (in.)	P Piston Rod Thread (NPTF)	Q Piston Rod Thread (NPTF)	Bore Dia. (in.)	Cyl. Eff. Area (sq. in.)	Internal Pressure at Cap. (psi)	Tons at 10,000 psi Pull	Prod. Wt. (lbs.)
2	5	RP25	2.76	9 ⁹ / ₁₆	14 ⁹ / ₁₆	1 ³ / ₄	1 ¹ / ₂ -16	1	1 ¹¹ / ₁₆	3/4	1	3/4-14	3/4-14	1 ¹ / ₈	0.55	7,250	2.75	4
5	5 ¹ / ₂	RP55	6.22	11 ⁷ / ₈	17 ³ / ₈	2 ¹ / ₄	2 ¹ / ₄ -14	1	1 ¹¹ / ₁₆	1 ³ / ₁₆	1 ³ / ₈	1 ¹ / ₄ -11 ¹ / ₂	1 ¹ / ₄ -11 ¹ / ₂	1 ¹¹ / ₁₆	1.13	8,850	5.65	11

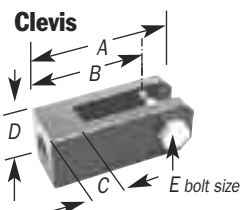

Clevis ORDERING INFORMATION

Use with Cyl. No.	Order No.	A (in.)	B (in.)	C (in.)	D (in.)	E (in.)
RP25	421057*	5 ¹ / ₈	4 ⁵ / ₁₆	1 ⁵ / ₁₆	2	3/4
RP55	421056**	6	5	1 ¹ / ₂	2 ¹ / ₂	7/8

* For base mounting, extension rod 351106 is required.
** For base mounting, extension rod 351075 is required.

DOUBLE ACTING

RD Series

10-500 Ton

Double Acting, Hydraulic-Return



CYLINDERS

HIGH TONNAGE PREMIUM DESIGN FOR HIGH CYCLE LIFE.

- Perfect for bridge lifting, building reconstruction, shipyard, utility and mining equipment maintenance.
- Aluminum bronze overlay bearings provide long life, chrome plated piston rod resists corrosion.
- Load cap snaps out to expose internal piston rod threads for pulling applications; threads withstand full tonnage.
- Grooved ring pattern in load cap helps guard against load slippage.
- Each cylinder has two 9796 3/8" NPTF female half couplers.
- Built-in safety relief valve prevents over-pressurization of the retract circuit.
- Feature mounting holes and collar threads.



Four special order 500 ton, 24" stroke cylinders used in a swaging press for crimping 3 1/2" wire rope.



RD10013

ASME B30.1
10,000 PSI



RD300



RD556

Features of RD Series Cylinders

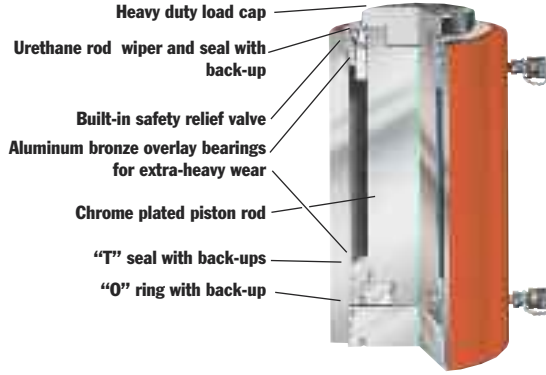

Threads withstand full load.

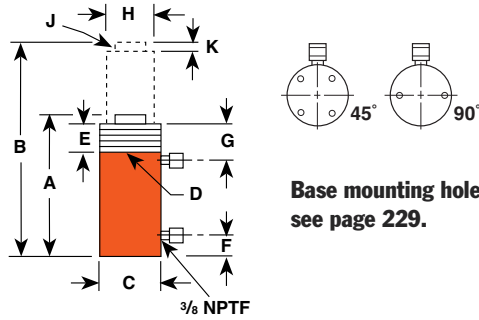
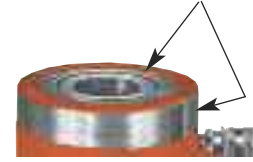

Base mounting holes see page 229.

Cyl. Cap (tons)	Stroke (in.)	Order No.	Oil Capacity (cu.in.)		A Re-tracted Height (in.)	B Ex-tended Height (in.)	C Out-side Dia. (in.)	D Collar Thread Size (in.)	E Thread Length (in.)	F Base Port (in.)	G Cylinder Top to Port (in.)	H Piston Rod Dia. (in.)	J Rod Int. and (in.)	K Piston Rod Pro-trusion (in.)	Load Cap		Cyl. Eff. Area (sq.in.)		Int. Press. at Cap.		Tons at 10,000 psi		Prod. Wt. (lbs.)	
			Push	Pull											Push	Pull	Push	Pull	Push	Pull	Push	Pull		
			Push	Pull											Push	Pull	Push	Pull	Push	Pull	Push	Pull		
10	4	6 ¹ / ₄	RD106	13.9	5.5	11 ¹¹ / ₁₆	17 ¹⁵ / ₁₆	3	2 ³ / ₄ -12	1 ⁵ / ₈	1	2 ¹ / ₂	1 ⁵ / ₁₆	1-8x1	1 ¹ / ₄	1 ³ / ₈	1 ¹¹ / ₁₆	2.23	0.88	8,943	9,055	11.2	4.4	22
10	4	10	RD1010	22.3	8.8	15 ¹¹ / ₁₆	25 ¹¹ / ₁₆	3	2 ³ / ₄ -12	1 ⁵ / ₈	1	2 ¹ / ₂	1 ⁵ / ₁₆	1-8x1	1 ¹ / ₄	1 ³ / ₈	1 ¹¹ / ₁₆	2.23	0.88	8,943	9,055	11.2	4.4	28
25	8	6 ¹ / ₄	RD256	32.2	10.1	12 ³ / ₈	18 ⁵ / ₈	4	4-12	1 ⁵ / ₈	1	2 ¹ / ₂	2 ¹ / ₈	1 ¹ / ₂ -16x1	3 ¹ / ₈	2 ¹ / ₈	2 ⁹ / ₁₆	5.15	1.61	9,695	9,934	25.8	8.0	39.8
25	8	14 ¹ / ₄	RD2514	73.5	22.9	20 ³ / ₈	34 ⁵ / ₈	4	4-12	1 ⁵ / ₈	1	2 ¹ / ₂	2 ¹ / ₈	1 ¹ / ₂ -16x1	3 ¹ / ₈	2 ¹ / ₈	2 ⁹ / ₁₆	5.15	1.61	9,695	9,934	25.8	8.0	65
55	28	6 ¹ / ₄	RD556	69.0	35.2	12 ³¹ / ₃₂	19 ⁷ / ₃₂	5	5-12	1 ⁵ / ₈	1 ⁵ / ₁₆	2 ¹ / ₂	2 ⁵ / ₈	1 ¹¹ / ₁₆ -8X1 ³ / ₁₆	5 ⁵ / ₈	2 ⁵ / ₈	3 ³ / ₄	11.04	5.63	9,959	9,941	55.2	28.2	61.4
55	28	13 ¹ / ₈	RD5513	144.9	73.9	19 ²⁷ / ₃₂	32 ³¹ / ₃₂	5	5-12	1 ⁵ / ₈	1 ⁵ / ₁₆	2 ¹ / ₂	2 ⁵ / ₈	1 ¹¹ / ₁₆ -8X1 ³ / ₁₆	5 ⁵ / ₈	2 ⁵ / ₈	3 ³ / ₄	11.04	5.63	9,959	9,941	55.2	28.2	90
55	28	18 ¹ / ₈	RD5518	200.0	102.0	25 ⁷ / ₈	44	5	5-12	1 ⁵ / ₈	1 ⁵ / ₁₆	2 ¹ / ₂	2 ⁵ / ₈	1 ¹¹ / ₁₆ -8X1 ³ / ₁₆	5 ⁵ / ₈	2 ⁵ / ₈	3 ³ / ₄	11.04	5.63	9,959	9,941	55.2	28.2	142
80	44	13 ¹ / ₈	RD8013	208.6	115.9	20 ³ / ₈	33 ¹ / ₂	5 ³ / ₄	5 ³ / ₄ -12	1 ⁵ / ₈	1 ¹ / ₂	2 ¹ / ₂	3	2-4 ¹ / ₂ x1 ¹ / ₂	9 ¹ / ₁₆	2 ⁷ / ₈	4 ¹ / ₂	15.90	8.84	10,060	9,954	79.5	44.2	118
100	44	6 ⁵ / ₈	RD1006	136.7	58.5	13 ²⁵ / ₃₂	20 ¹³ / ₃₂	6 ⁷ / ₈	6 ⁷ / ₈ -12	1 ⁵ / ₈	1 ¹ / ₂	2 ¹ / ₂	3 ⁷ / ₈	2 ³ / ₄ -12x1 ⁵ / ₃₂	5 ⁵ / ₈	3 ⁷ / ₈	5 ¹ / ₈	20.63	8.84	9,695	9,959	103.1	44.2	126
100	44	13 ¹ / ₈	RD10013	270.7	116.0	20 ⁹ / ₃₂	33 ¹³ / ₃₂	6 ⁷ / ₈	6 ⁷ / ₈ -12	1 ⁵ / ₈	1 ¹ / ₂	2 ¹ / ₂	3 ⁷ / ₈	2 ³ / ₄ -12x1 ⁵ / ₃₂	5 ⁵ / ₈	3 ⁷ / ₈	5 ¹ / ₈	20.63	8.84	9,695	9,959	103.1	44.2	181
100	44	20 ¹ / ₈	RD10020	415.2	178.0	28 ⁹ / ₃₂	48 ¹³ / ₃₂	6 ⁷ / ₈	6 ⁷ / ₈ -12	1 ⁵ / ₈	1 ¹ / ₂	2 ¹ / ₂	3 ⁷ / ₈	2 ³ / ₄ -12x1 ⁵ / ₃₂	5 ⁵ / ₈	3 ⁷ / ₈	5 ¹ / ₈	20.63	8.84	9,695	9,959	103.1	44.2	260
150	73	6 ⁵ / ₈	RD1506	203.3	97.9	14 ⁷ / ₈	21 ¹ / ₂	8 ¹ / ₄	8 ¹ / ₄ -12	1 ⁵ / ₈	2	2 ¹ / ₂	4 ¹ / ₂	3 ¹ / ₄ +8x1 ¹ / ₂	1 ¹³ / ₁₆	4 ¹ / ₂	6 ¹ / ₄	30.68	14.78	9,779	9,880	153.4	73.8	188
150	73	13 ¹ / ₈	RD15013	402.7	193.9	21 ³ / ₈	34 ¹ / ₂	8 ¹ / ₄	8 ¹ / ₄ -12	1 ⁵ / ₈	2	2 ¹ / ₂	4 ¹ / ₂	3 ¹ / ₄ +8x1 ¹ / ₂	1 ¹³ / ₁₆	4 ¹ / ₂	6 ¹ / ₄	30.68	14.78	9,779	9,880	153.4	73.8	272
150	73	18 ¹ / ₈	RD15018	556.8	267.8	26 ¹⁷ / ₃₂	44 ²¹ / ₃₂	8 ¹ / ₄	8 ¹ / ₄ -12	1 ⁵ / ₈	2	2 ¹ / ₂	4 ¹ / ₂	3 ¹ / ₄ +8x1 ¹ / ₂	3 ³ / ₄	4 ¹ / ₂	6 ¹ / ₄	30.68	14.78	9,779	9,880	153.4	73.8	376
200	113	6 ⁵ / ₈	RD2006	273.5	149.8	16	22 ⁵ / ₈	9 ¹ / ₂	9 ¹ / ₂ -12	1 ⁵ / ₈	2 ¹ / ₂	2 ¹¹ / ₁₆	4 ⁷ / ₈	3 ¹ / ₄ +8x2 ¹ / ₄	1 ¹ / ₁₆	4 ¹ / ₂	7 ¹ / ₄	41.28	22.62	9,689	9,992	206.4	113.1	262
200	113	13 ¹ / ₈	RD20013	541.8	296.9	22 ¹ / ₂	35 ⁵ / ₈	9 ¹ / ₂	9 ¹ / ₂ -12	1 ⁵ / ₈	2 ¹ / ₂	2 ¹¹ / ₁₆	4 ⁷ / ₈	3 ¹ / ₄ +8x2 ¹ / ₄	1 ¹ / ₁₆	4 ¹ / ₂	7 ¹ / ₄	41.28	22.62	9,689	9,992	206.4	113.1	356
200	113	18 ¹ / ₈	RD20018	748.2	409.9	28 ¹ / ₂	46 ⁵ / ₈	9 ¹ / ₂	9 ¹ / ₂ -12	1 ⁵ / ₈	2 ¹ / ₂	2 ¹¹ / ₁₆	4 ⁷ / ₈	3 ¹ / ₄ +8x2 ¹ / ₄	1 ¹ / ₁₆	4 ¹ / ₂	7 ¹ / ₄	41.28	22.62	9,689	9,992	206.4	113.1	442
300	147	6	RD3006	361.0	177.0	17 ⁹ / ₃₂	23 ⁹ / ₃₂	10 ³ / ₄	10 ¹ / ₂ -12	2 ³ / ₈	3 ³ / ₈	3 ³ / ₈	6 ¹ / ₄	2 ¹ / ₂ -12x3 ¹ / ₄	1 ¹ / ₈	6 ¹ / ₈	8 ³ / ₄	60.13	29.45	9,978	10,000	300.7	147.3	380
300	147	13	RD30013	782.0	383.0	24 ¹³ / ₁₆	37 ¹³ / ₁₆	10 ³ / ₄	10 ¹ / ₂ -12	2 ³ / ₈	3 ³ / ₈	3 ³ / ₈	6 ¹ / ₄	2 ¹ / ₂ -12x3 ¹ / ₄	1 ¹ / ₈	6 ¹ / ₈	8 ³ / ₄	60.13	29.45	9,978	10,000	300.7	147.3	654
400	186	6	RD4006	471.0	247.0	19 ³ / ₃₂	25 ³ / ₃₂	12 ⁵ / ₈	12 ¹ / ₂ -8	2 ³ / ₈	3 ²⁷ / ₃₂	3 ²⁷ / ₃₂	7 ¹ / ₄	3-12x3 ³ / ₄	1 ¹ / ₄	7 ¹³ / ₁₆	10	78.54	37.26	10,185	10,000	392.7	186.3	585
400	186	13	RD40013	1021.0	536.0	26 ³ / ₃₂	39 ³ / ₃₂	12 ⁵ / ₈	12 ¹ / ₂ -8	2 ³ / ₄	3 ²⁷ / ₃₂	3 ²⁷ / ₃₂	7 ¹ / ₄	3-12x3 ³ / ₄	1 ¹ / ₄	7 ¹³ / ₁₆	10	78.54	37.26	10,185	10,000	392.7	186.3	770
500	245	6	RD5006	596.0	295.0	20 ⁹ / ₁₆	26 ³ / ₁₆	14 ³ / ₄	14 ³ / ₄ -8	3 ¹ / ₈	4 ⁵ / ₃₂	4 ⁵ / ₃₂	8	3 ¹ / ₄ -12x4 ¹ / ₄	1 ¹ / ₂	8 ¹ / ₂	11 ¹ / ₄	99.40	49.14	10,060	10,000	497.0	245.6	819
500	245	13	RD50013	1292.0	639.0	27 ⁹ / ₁₆	40 ⁹ / ₁₆	14 ³ / ₄	14 ³ / ₄ -8	3 ¹ / ₈	4 ⁵ / ₃₂	4 ⁵ / ₃₂	8	3 ¹ / ₄ -12x4 ¹ / ₄	1 ¹ / ₂	8 ¹ / ₂	11 ¹ / ₄	99.40	49.14	10,060	10,000	497.0	245.6	1092

HIGH TONNAGE

R Series

55-565 Ton

Single-Acting Load-Return



CYLINDERS

HIGH-TONNAGE, LOW CYCLE, HYDRAULIC RETURN.

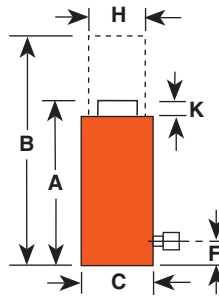

R2802C

ASME B30.1
10,000 PSI

- Visible indicator band alerts when stroke limit is reached; overflow port ("weep hole") stroke limiter prevents piston from being overextended.
- Alloy heat treated piston and body for reliability and strength.
- Plated piston rod increases corrosion resistance and gives superior bearing support.

Cyl. Cap. (tons)	Stroke (in.)	Order No.	Oil Cap. (cu. in.)	A	B	C	F	H	K	Bore Dia. (in.)	Cylinder Effective Area (sq. in.)	Internal Pressure at Cap. (psi)	Tons at 10,000 psi	Product Wt. (lbs.)
				Retracted Ht. (in.)	Extended Ht. (in.)	Outside Dia. (in.)	Base Port (in.)	Piston Rod Dia. (in.)	Piston Rod Protrusion (in.)					
55	2	R552C	22.1	4 ¹⁵ / ₁₆	6 ¹⁵ / ₁₆	5	1	3 ³ / ₄	1 ¹ / ₈	3 ³ / ₄	11.04	9,960	55.2	27
55	6	R556C	66.3	8 ¹⁵ / ₁₆	14 ¹⁵ / ₁₆	5	1	3 ³ / ₄	1 ¹ / ₈	3 ³ / ₄	11.04	9,960	55.2	50
55	10	R5510C	110.4	12 ¹⁵ / ₁₆	22 ¹⁵ / ₁₆	5	1	3 ³ / ₄	1 ¹ / ₈	3 ³ / ₄	11.04	9,960	55.2	72
100	2	R1002C	41.3	5 ¹ / ₂	7 ¹ / ₂	6 ¹ / ₂	1	5 ¹ / ₈	1 ¹ / ₈	5 ¹ / ₈	20.63	9,695	103.2	52
100	6	R1006C	123.8	9 ¹ / ₂	15 ¹ / ₂	6 ¹ / ₂	1	5 ¹ / ₈	1 ¹ / ₈	5 ¹ / ₈	20.63	9,695	103.2	89
150	2	R1502C	61.4	6 ³ / ₈	8 ³ / ₈	8 ¹ / ₁₆	1 ¹ / ₄	6 ¹ / ₄	1 ¹ / ₈	6 ¹ / ₄	30.68	9,778	153.4	92
150	6	R1506C	184.1	10 ³ / ₈	16 ³ / ₈	8 ¹ / ₁₆	1 ¹ / ₄	6 ¹ / ₄	1 ¹ / ₈	6 ¹ / ₄	30.68	9,778	153.4	151
150	10	R15010C	306.8	14 ³ / ₈	24 ³ / ₈	8 ¹ / ₁₆	1 ¹ / ₄	6 ¹ / ₄	1 ¹ / ₈	6 ¹ / ₄	30.68	9,778	153.4	210
200	2	R2002C	82.6	7 ¹ / ₂	9 ¹ / ₂	9 ¹ / ₄	1 ⁵ / ₈	7 ¹ / ₄	1 ¹ / ₈	7 ¹ / ₄	41.28	9,690	206.4	145
200	6	R2006C	247.7	11 ¹ / ₂	17 ¹ / ₂	9 ¹ / ₄	1 ⁵ / ₈	7 ¹ / ₄	1 ¹ / ₈	7 ¹ / ₄	41.28	9,690	206.4	221
280	2	R2802C	113.5	7 ¹ / ₂	9 ¹ / ₂	10 ¹ / ₄	1 ⁵ / ₈	8 ¹ / ₂	1 ¹ / ₈	8 ¹ / ₂	56.74	9,870	283.7	201
280	6	R2806C	340.4	11 ¹ / ₂	17 ¹ / ₂	10 ⁷ / ₈	1 ⁵ / ₈	8 ¹ / ₂	1 ¹ / ₈	8 ¹ / ₂	56.74	9,870	283.7	300
355	2	R3552C	141.8	9 ¹ / ₈	11 ¹ / ₈	11 ³ / ₄	2 ¹ / ₈	9 ¹ / ₂	1 ¹ / ₈	9 ¹ / ₂	70.88	10,017	354.4	302
355	6	R3556C	425.3	13 ¹ / ₈	19 ¹ / ₈	11 ³ / ₄	2 ¹ / ₈	9 ¹ / ₂	1 ¹ / ₈	9 ¹ / ₂	70.88	10,017	354.4	434
355	10	R35510C	708.8	17 ¹ / ₈	27 ¹ / ₈	11 ³ / ₄	2 ¹ / ₈	9 ¹ / ₂	1 ¹ / ₈	9 ¹ / ₂	70.88	10,017	354.4	565
430	2	R4302C	173.2	10 ³ / ₈	12 ³ / ₈	13	2 ¹ / ₂	10 ¹ / ₂	1 ¹ / ₈	10 ¹ / ₂	86.59	9,932	433.0	440
430	6	R4306C	519.5	14 ³ / ₈	20 ³ / ₈	13	2 ¹ / ₂	10 ¹ / ₂	1 ¹ / ₈	10 ¹ / ₂	86.59	9,932	433.0	609
565	2	R5652C	226.2	11 ¹ / ₂	13 ¹ / ₂	14 ⁷ / ₈	2 ³ / ₄	12	1 ¹ / ₈	12	113.10	9,991	565.5	638
565	6	R5656C	678.6	15 ¹ / ₂	21 ¹ / ₂	14 ⁷ / ₈	2 ³ / ₄	12	1 ¹ / ₈	12	113.10	9,991	565.5	858
565	10	R56510C	1131.0	19 ¹ / ₂	29 ¹ / ₂	14 ⁷ / ₈	2 ³ / ₄	12	1 ¹ / ₈	12	113.10	9,991	565.5	1078

For use with "RC" cylinders

Use with Cyl. No.	Swivel Cap Order No.	Wt. (lbs.)
150-200 ton	420867	8.8
280 ton	420868	13.5
355 ton	420869	37
430 ton	420870	52
565 ton	420871	78

SWIVEL CAPS

Reduce the effects of off center loading. Tilts up to 5 degrees. Radial grooves on top of cap reduce load slippage.

A (in.)	B (in.)
1 ¹ / ₂	5 ¹ / ₈
1 ³ / ₄	5 ⁷ / ₈
2 ³ / ₄	7 ¹¹ / ₁₆
3 ¹ / ₈	8 ⁷ / ₈
3 ⁵ / ₈	9 ⁷ / ₈

Reduce the effects of off-center loading. Tilts up to 5 degrees. Radial grooves on top of cap reduce load slippage. Notch across face of each cap helps keep loads having a protruding or round shaped centered.

26

POWER TEAM

HIGH TONNAGE

RC Series

740 - 1220 Ton

Single-Acting, Load Return

HIGH-TONNAGE, LOW CYCLE, GRAVITY RETURN.

- Overflow port (“weep hole”) prevents piston from being overextended under load.
- Alloy heat treated piston and body for reliability and strength.
- Plated piston rod increases corrosion resistance and gives superior bearing support.



CYLINDERS

Single-Acting High Tonnage Cylinders

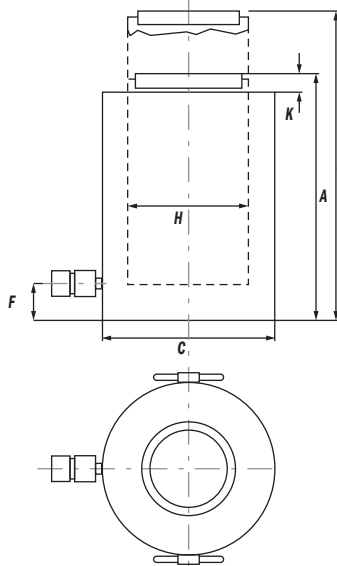

Swivel Cap

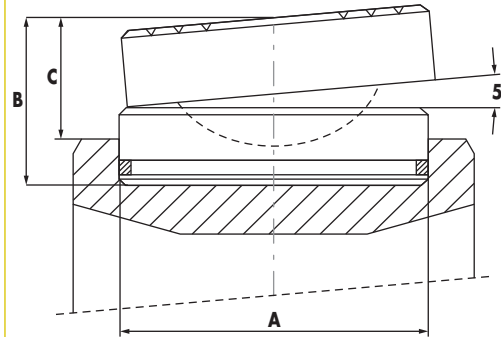

Order No.	Used with Cyl. Order No.	A in.	B in.	C in.	Product Wt. lbs.
2000824	RC740*C, RC965*C,	11.4	5.5	3.9	158.7
2000825	RC1220*C	12.7	6.9	4.9	249.1

In mm Cyl. Cap. (tons)	Stroke (in.)	Order No. (Cu. in.)	Oil Cap. (in.)	A Retracted Height (in.)	B Extended Height (in.)	C Outside Dia. (in.)	F Base to Port (in.)	H Piston Rod Dia. (in.)	K Piston Rod Protrusion (in.)	Bore Dia. (in.)	Cyl. Effective Area (cu. in.)	Tons @ 10,000 psi	Product Wt. (lbs.)
740	2.0	RC7402C	293.6	10.4	12.4	16.9	2.6	13.8	0.4	13.8	149.1	742	661
740	6.0	RC7406C 8	80.7	14.4	20.3	16.9	2.6	13.8	0.4	13.8	149.1	742	917
740	10	RC74010C	1,467.8	18.3	28.1	16.9	2.6	13.8	0.4	13.8	149.1	742	1,168
965	2.0	RC9652C	383.2	11.4	13.4	19.3	2.8	15.7	0.4	15.7	194.8	970	933
965	6.0	RC9656C	1,150.2	15.4	21.3	19.3	2.8	15.7	0.4	15.7	194.8	970	1,272
965	10	RC96510C	1,916.2	19.3	29.1	19.3	2.8	15.7	0.4	15.7	194.8	970	1,598
1220	2.0	RC12202C	485.1	16.3	18.1	21.7	3.1	17.7	0.4	17.7	246.5	1227	1,689
1220	6.0	RC12206C	1,455.8	20.2	26.1	21.7	3.1	17.7	0.4	17.7	246.5	1227	2,116
1220	10	RC122010C 2,	452.2	24.4	34.2	21.7	3.1	17.7	0.4	17.7	246.5	1227	2,529

HIGH TONNAGE

R Series

100-565 Ton

Double-Acting, Hydraulic-Return



CYLINDERS

HIGH-TONNAGE, LOW CYCLE, HYDRAULIC RETURN.

- Cylinders come standard with swivel caps to reduce the effects of off-center loading.
- Cylinders may be “dead-ended” without damage.
- Hard chrome plated, heat treated piston rod reduces wear on piston and gland nut.
- Built-in safety relief valve prevents over-pressurization of the retract circuit.
- Each cylinder has two 9796 3/8" NPTF female half couplers.



R2806D

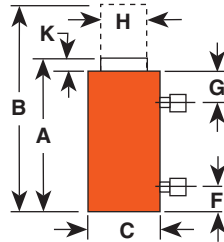

R1502D

Cyl. Cap. (tons)	Order Stroke (in.)	Order No.	Oil Capacity (cu. in.)		A Re-tracted Height (in.)	B Ex-tended Dia. (in.)	C Outside Port (in.)	F Base to Port (in.)	G Cylinder Top to Dia. (in.)	H Piston Rod Dia. (in.)	K Piston Rod Protrusion (in.)	Cylinder				
			Push	Return								Bore Area (in.)	Effective Press. (sq. in.)	Internal 10,000 at Cap. (sq. in.)	Tons at Cap. (psi)	Prod. (lbs.)
100	2	R1002D	41.2	19.2	6 ^{41/64}	8 ^{41/64}	6 ^{1/2}	1	2 ^{13/64}	3 ^{3/4}	9 ^{9/32}	5 ^{1/8}	20.60	9,695	103.0	54
100	6	R1006D	123.6	57.6	10 ^{41/64}	16 ^{41/64}	6 ^{1/21}	1	2 ^{13/64}	3 ^{3/4}	9 ^{9/32}	5 ^{1/8}	20.60	9,695	103.0	81
100	10	R10010D	206.0	96.0	14 ^{41/64}	24 ^{41/64}	6 ^{1/2}	1	2 ^{13/64}	3 ^{3/4}	9 ^{9/32}	5 ^{1/8}	20.60	9,695	103.0	108
150	2	R1502D	61.4	29.6	7 ^{7/16}	9 ^{7/16}	8 ^{1/16}	1 ^{1/4}	2 ^{1/4}	4 ^{1/2}	19 ^{19/64}	6 ^{1/4}	30.70	9,778	153.4	95
150	6	R1506D	184.2	88.8	11 ^{7/16}	17 ^{7/16}	8 ^{1/16}	1 ^{1/4}	2 ^{1/4}	4 ^{1/2}	19 ^{19/64}	6 ^{1/4}	30.70	9,778	153.4	136
200	2	R2002D	82.6	39.2	8 ^{9/64}	10 ^{9/64}	9 ^{1/4}	1 ^{5/8}	2 ^{5/16}	5 ^{1/4}	11 ^{11/32}	7 ^{1/4}	41.30	9,690	206.4	136
200	6	R2006D	247.8	117.6	12 ^{9/64}	18 ^{9/64}	9 ^{1/4}	1 ^{5/8}	2 ^{5/16}	5 ^{1/4}	11 ^{11/32}	7 ^{1/4}	41.30	9,690	206.4	187
200	10	R20010D	413.0	196.0	16 ^{9/64}	26 ^{9/64}	9 ^{1/4}	1 ^{5/8}	2 ^{5/16}	5 ^{1/4}	11 ^{11/32}	7 ^{1/4}	41.30	9,690	206.4	239
280	2	R2802D	113.4	47.2	9 ^{13/64}	11 ^{13/64}	10 ^{7/8}	1 ^{7/8}	2 ^{37/64}	6 ^{1/2}	13 ^{13/32}	8 ^{1/2}	56.70	9,870	283.7	219
280	6	R2806D	340.2	141.6	13 ^{13/64}	19 ^{13/64}	10 ^{7/8}	1 ^{7/8}	2 ^{37/64}	6 ^{1/2}	13 ^{13/32}	8 ^{1/2}	56.70	9,870	283.7	297
280	10	R28010D	567.0	236.0	17 ^{13/64}	27 ^{13/64}	10 ^{7/8}	1 ^{7/8}	2 ^{37/64}	6 ^{1/2}	13 ^{13/32}	8 ^{1/2}	56.70	9,870	283.7	376
355	2	R3552D	141.8	47.4	11 ^{3/8}	13 ^{3/8}	11 ^{3/4}	2 ^{5/8}	2 ^{3/4}	7 ^{3/4}	7 ^{7/16}	9 ^{1/2}	70.90	10,017	354.4	324
355	6	R3556D	425.4	142.2	15 ^{3/8}	21 ^{3/8}	11 ^{3/4}	2 ^{5/8}	2 ^{3/4}	7 ^{3/4}	7 ^{7/16}	9 ^{1/2}	70.90	10,017	354.4	421
430	2	R4302D	173.2	59.6	12 ^{5/16}	14 ^{5/16}	13	2 ^{1/2}	2 ^{61/64}	8 ^{1/2}	15 ^{15/32}	10 ^{1/2}	86.60	9,932	433.0	439
430	6	R4306D	519.6	178.8	16 ^{5/16}	22 ^{5/16}	13	2 ^{1/2}	2 ^{61/64}	8 ^{1/2}	15 ^{15/32}	10 ^{1/2}	86.60	9,932	433.0	558
430	10	R43010D	866.0	298.0	20 ^{5/16}	30 ^{5/16}	13	2 ^{1/2}	2 ^{61/64}	8 ^{1/2}	15 ^{15/32}	10 ^{1/2}	86.60	9,932	433.0	673
565	2	R5652D	226.2	76.8	13 ^{19/32}	15 ^{19/32}	14 ^{7/8}	2 ^{3/4}	3 ^{13/64}	9 ^{3/4}	35 ^{35/64}	12	113.10	9,991	565.5	619
565	6	R5656D	678.6	230.4	17 ^{19/32}	23 ^{19/32}	14 ^{7/8}	2 ^{3/4}	3 ^{13/64}	9 ^{3/4}	35 ^{35/64}	12	113.10	9,991	565.5	772
565	10	R56510D	1131.0	384.0	21 ^{19/32}	31 ^{19/32}	14 ^{7/8}	2 ^{3/4}	3 ^{13/64}	9 ^{3/4}	35 ^{35/64}	12	113.10	9,991	565.5	926

HIGH TONNAGE

RC Series

740 & 1220

Double-Acting, Hydraulic Return

HIGH TONNAGE CYLINDERS RUGGED AND RELIABLE

- Cylinders come standard with hardened caps.
- Optional swivel caps to reduce the effects of off-center loading.
- Cylinders may be “dead-ended” without damage.
- Safety relief valve prevents over-pressurization of the retract circuit.
- Each cylinder has two 9796 3/8" NPTF female half couplers.



CYLINDERS

Double-Acting High Tonnage Cylinders

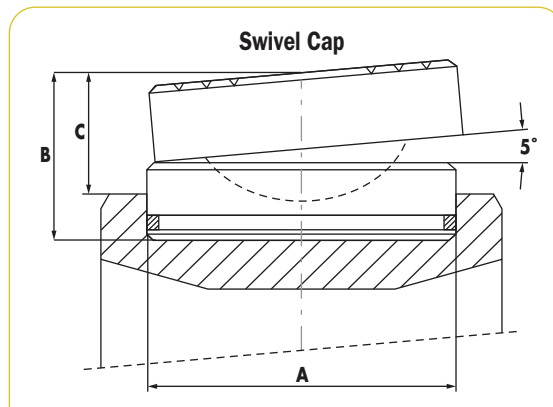
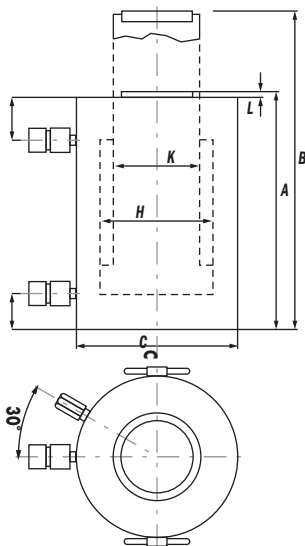

Order No.	Used with Cyl. Order No.	A in.	B in.	C in.	Product Wt. lbs.
2000822	RC740*D	7.9	3.1	2.2	42.5
2000823	RC965*D	9.8	4.1	3.0	88.2
2000825	RC1220*D	12.7	6.9	4.9	249.1

In mm Cyl. Cap. (tons)	Stroke (in.)	Order No.	Oil Cap. (cu. in.)	A Retracted Height (in.)	B Extended Height (in.)	C Outside Dia. (in.)	F Base to Port (in.)	G Cyl. Top to Port (in.)	H Bore Dia. (in.)	K Piston Rod Dia. (in.)	L Piston Rod Protrusion (in.)	Cyl. Effective Area (cu. in.)	10,000 psi	Product Wt.
740	2.0	RC7402D	293.6	11.1	13.1	16.9	2.6	3.9	13.8	11.01	0.4	149.1	742	670
740	6	RC7406D	880.7	15.7	21.6	16.9	2.6	3.9	13.8	11.01	0.4	149.1	742	877
740	10	RC74010D	1,467.8	20.0	29.8	16.9	2.6	3.9	13.8	11.01	0.4	149.1	742	1080
965	2.0	RC9652D	383.2	12.2	14.2	19.3	2.8	4.5	15.7	14.17	0.4	194.8	970	957
965	6	RC9656D	1,150.2	16.5	22.4	19.3	2.8	4.5	15.7	14.17	0.4	194.8	970	1,215
965	10	RC96510D	1,916.2	20.9	30.7	19.3	2.8	4.5	15.7	14.17	0.4	194.8	970	1,473
1220	2.0	RC12202D	485.1	13.0	15.0	21.7	3.1	5.3	17.7	14.17	0.4	246.5	1227	1,287
1220	6	RC12206D	1,455.8	17.3	23.2	21.7	3.1	5.3	17.7	14.17	0.4	246.5	1227	1,612
1220	10	RC122010D	2,452.2	21.7	31.5	21.7	3.1	5.3	17.7	14.17	0.4	246.5	1227	1,936

LOCKING COLLAR

RL Series– Aluminum

55 & 100 Ton Single- Acting,
Spring-Return



CYLINDERS



Locking collar feature permits non-hydraulic support of load.



RA1006L



RA556L

ASME B30.1
10,000 PSI

POSITIVE MECHANICAL LOCK TO SUPPORT LOAD.

- Supports lifted load for extended periods of time with hydraulic pressure released.
- At half the weight of steel cylinders of comparable capacity, aluminum cylinders are ideal when portability is a key factor.
- Feature carrying handle.

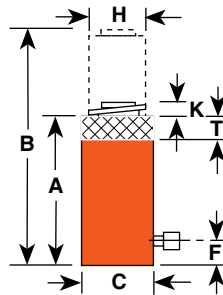

Cyl. Cap. (tons)	Order No.	Oil Cap. (cu. in.)	Stroke (in.)	Dimensions							Bore Dia. (in.)	Cylinder Effective Area (sq. in.)	Internal Pressure at Cap. (psi)	Tons at 10,000 psi	Product Wt. (lbs.)
				A Retracted Ht. (in.)	B Extended Ht. (in.)	C Outside Dia. (in.)	F Base to Port (in.)	H Piston Rod Dia. (in.)	K Piston Rod Protrusion (in.)	T Nut Thickness (in.)					
55	RA556L	67.6	6 ⁷ / ₈	12 ¹ / ₂	18 ⁵ / ₈	5 ¹ / ₄	1 ³ / ₈	3 ³ / ₄	1 ¹ / ₂	1 ¹ / ₂	3 ³ / ₄	11.04	9,960	55.2	29.6
100	RA1006L	129	6 ³ / ₄	13 ³ / ₈	19 ⁵ / ₈	7 ³ / ₈	1 ³ / ₁₆	4 ¹ / ₂	1 ¹ / ₄	1 ¹ / ₂	5 ¹ / ₈	20.62	9,696	103.1	64.0

Note: Supported loads not to exceed the rated capacity of the cylinders. Not intended to support additional dynamic loads, such as those applied by moving vehicles.

PANCAKE CYLINDERS

Locking Collar RC Series 55 & 620 Ton

POSITIVE MECHANICAL LOCK TO SUPPORT LOAD.

- Compact design - for use where space is limited.
- Locking collar designed to support lifted load for extended periods of time with hydraulic pressure released.
- Integral tilt saddle standard improves performance under side load.
- Overflow port (“weep hole”) prevents piston from being overextended under load.
- Special coating improves corrosion and abrasion resistance.
- Cylinders come standard with hardened swivel caps reducing the effects of off-center loading Single-Acting Locking Collar Cylinders.
- Equipped with 3/8" NPTF female half couplers.

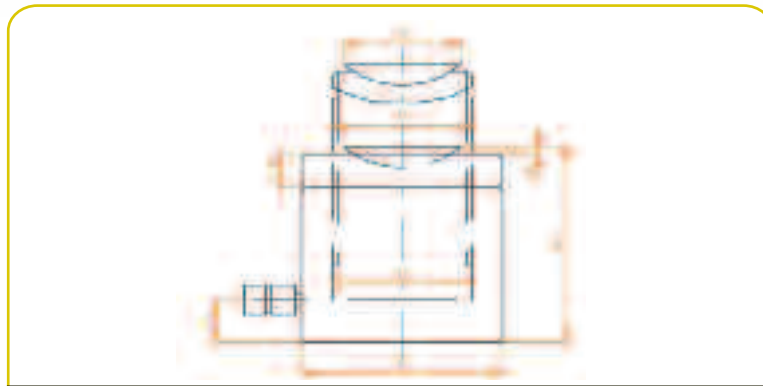

Cyl. Cap. (tons)	Stroke	Order No.	Oil Cap. (cm ³)	A Retracted Height (in.)	B Outside Dia. (in.)	C Piston Rod Dia. (in.)	D Bore Dia. (in.)	E Base to Port (in.)	F Nut Thickness (in.)	G Swivel Cap Protrusion (in.)	H Swivel Cap Dia. (in.)	Product Wt. (lbs.)
55	2	RC0552P	21.66	4.92	4.72	3.74	3.74	.75	.83	.24	3.62	24.25
100	1.75	RC1002P	36.43	5.39	6.5	5.12	5.12	.83	1.22	.31	4.96	48.50
155	1.75	RC1552P	55.23	5.83	8.07	6.30	6.30	1.06	1.50	.35	5.83	85.98
240	1.75	RC2402P	86.23	6.10	10.04	7.87	7.87	1.10	1.57	.39	6.18	130.07
380	1.75	RC3802P	134.74	7.01	12.60	9.84	9.84	1.38	1.97	.43	9.45	242.51
620	1.75	RC6202P	220.78	7.56	15.94	12.60	12.60	1.50	2.36	.39	11.61	425.49

LOCKING COLLAR

RL Series STEEL

55 -565 Ton

Single- Acting, Load-Return



CYLINDERS

POSITIVE MECHANICAL LOCK TO SUPPORT LOAD.

- Supports lifted load for extended periods of time with hydraulic pressure released.
- Visible indicator band alerts when stroke limit is reached; overflow port ("weep hole") stroke limiter prevents piston from being overextended.
- All cylinders feature coated pistons to resist corrosion and abrasion.



R556L



Locking collar feature permits non-hydraulic support of load.

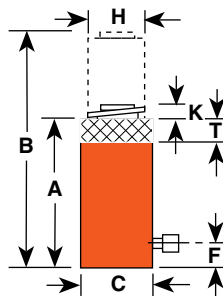

Cyl. Cap. (tons)	Stroke (in.)	Order No.	Oil Cap. (cu. in.)	A	B	C	F	H	K	T	Bore Dia. (in.)	Cylinder Effective Area (sq. in.)	Internal Pressure at Cap. (psi)	Tons at 10,000 psi	Product Wt. (lbs.)
				Retracted Ht. (in.)	Extended Ht. (in.)	Outside Dia. (in.)	Base to Port (in.)	Piston Rod Dia. (in.)	Piston Rod Protrusion (in.)	Nut Thickness (in.)					
55	2	R552L	22.10	6 ³ / ₈	8 ³ / ₈	4 ¹⁵ / ₁₆	1	3 ³ / ₄	1 ¹ / ₈	1 ⁷ / ₁₆	3 ³ / ₄	11.04	9,964	55.2	33.7
55	6	R556L	66.30	10 ³ / ₈	16 ³ / ₈	4 ¹⁵ / ₁₆	1	3 ³ / ₄	1 ¹ / ₈	1 ⁷ / ₁₆	3 ³ / ₄	11.04	9,964	55.2	58.0
55	10	R5510L	110.40	14 ³ / ₈	24 ³ / ₈	4 ¹⁵ / ₁₆	1	3 ³ / ₄	1 ¹ / ₈	1 ⁷ / ₁₆	3 ³ / ₄	11.04	9,964	55.2	80.0
100	2	R1002L	41.30	7 ¹ / ₄	9 ¹ / ₄	6 ¹ / ₂	1	5 ¹ / ₈	1 ¹ / ₈	1 ³ / ₄	5 ¹ / ₈	20.63	9,695	103.0	66.0
100	6	R1006L	123.80	11 ¹ / ₄	17 ¹ / ₄	6 ¹ / ₂	1	5 ¹ / ₈	1 ¹ / ₈	1 ³ / ₄	5 ¹ / ₈	20.63	9,695	103.0	103.0
100	10	R10010L	206.30	15 ¹ / ₄	25 ¹ / ₄	6 ¹ / ₂	1	5 ¹ / ₈	1 ¹ / ₈	1 ³ / ₄	5 ¹ / ₈	20.63	9,695	103.0	142.0
150	2	R1502L	61.40	8 ¹ / ₈	10 ¹ / ₈	8 ¹ / ₁₆	1 ¹ / ₄	6 ¹ / ₄	1 ¹ / ₈	1 ³ / ₄	6 ¹ / ₄	30.68	9,778	153.4	117.0
150	6	R1506L	184.10	12 ¹ / ₈	18 ¹ / ₈	8 ¹ / ₁₆	1 ¹ / ₄	6 ¹ / ₄	1 ¹ / ₈	1 ³ / ₄	6 ¹ / ₄	30.68	9,778	153.4	177.0
200	2	R2002L	82.60	9 ¹ / ₂	11 ¹ / ₂	9 ¹ / ₄	1 ⁵ / ₈	7 ¹ / ₄	1 ¹ / ₈	2	7 ¹ / ₄	41.28	9,690	206.4	183.0
200	6	R2006L	247.70	13 ¹ / ₂	19 ¹ / ₂	9 ¹ / ₄	1 ⁵ / ₈	7 ¹ / ₄	1 ¹ / ₈	2	7 ¹ / ₄	41.28	9,690	206.4	259.0
280	2	R2802L	113.50	9 ³ / ₄	11 ³ / ₄	10 ⁷ / ₈	1 ⁵ / ₈	8 ¹ / ₂	1 ¹ / ₈	2 ¹ / ₄	8 ¹ / ₂	56.74	9,870	283.7	261.0
280	6	R2806L	340.40	13 ³ / ₄	19 ³ / ₄	10 ⁷ / ₈	1 ⁵ / ₈	8 ¹ / ₂	1 ¹ / ₈	2 ¹ / ₄	8 ¹ / ₂	56.74	9,870	283.7	359.0
280	10	R28010L	567.40	17 ³ / ₄	27 ³ / ₄	10 ⁷ / ₈	1 ⁵ / ₈	8 ¹ / ₂	1 ¹ / ₈	2 ¹ / ₄	8 ¹ / ₂	56.74	9,870	283.7	459.0
355	2	R3552L	141.80	11 ¹ / ₂	13 ¹ / ₂	11 ³ / ₄	2 ¹ / ₈	9 ¹ / ₂	1 ¹ / ₈	2 ³ / ₈	9 ¹ / ₂	70.88	10,017	354.4	381.0
355	6	R3556L	425.30	15 ¹ / ₂	21 ¹ / ₂	11 ³ / ₄	2 ¹ / ₈	9 ¹ / ₂	1 ¹ / ₈	2 ³ / ₈	9 ¹ / ₂	70.88	10,017	354.4	512.0
430	2	R4302L	173.20	13 ¹ / ₈	15 ¹ / ₈	13	2 ¹ / ₂	10 ¹ / ₂	1 ¹ / ₈	2 ³ / ₄	10 ¹ / ₂	86.59	9,932	433.0	556.0
430	6	R4306L	519.50	17 ¹ / ₈	23 ¹ / ₈	13	2 ¹ / ₂	10 ¹ / ₂	1 ¹ / ₈	2 ³ / ₄	10 ¹ / ₂	86.59	9,932	433.0	725.0
430	10	R43010L	865.90	21 ¹ / ₈	31 ¹ / ₈	13	2 ¹ / ₂	10 ¹ / ₂	1 ¹ / ₈	2 ³ / ₄	10 ¹ / ₂	86.59	9,932	433.0	894.0
565	2	R5652L	226.20	14 ⁵ / ₈	16 ⁵ / ₈	14 ⁷ / ₈	2 ³ / ₄	12	1 ¹ / ₈	3 ¹ / ₈	12	113.10	9,991	565.5	811.0
565	6	R5656L	678.60	18 ⁵ / ₈	24 ⁵ / ₈	14 ⁷ / ₈	2 ³ / ₄	12	1 ¹ / ₈	3 ¹ / ₈	12	113.10	9,991	565.5	1031.0
565	10	R56510L	1131.0	22 ⁵ / ₈	32 ⁵ / ₈	14 ⁷ / ₈	2 ³ / ₄	12	1 ¹ / ₈	3 ¹ / ₈	12	113.10	9,991	565.5	1251.0

•NOTE: Supported loads not to exceed the rated capacity of the cylinders. Not intended to support additional dynamic loads, such as those applied by moving vehicles.

LOCKING COLLAR

RC SERIES

740 & 1220

Single-Acting, Load Return

POSITIVE MECHANICAL LOCK TO SUPPORT LOAD.



CYLINDERS

Single-Acting Locking Collar Cylinders

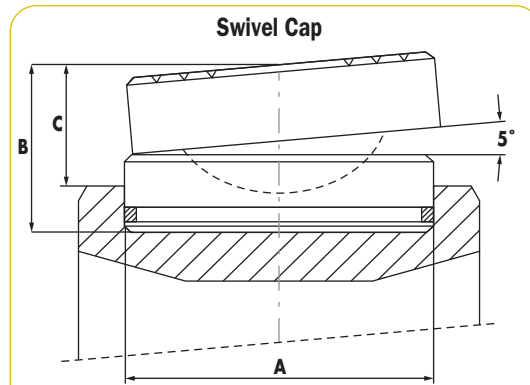
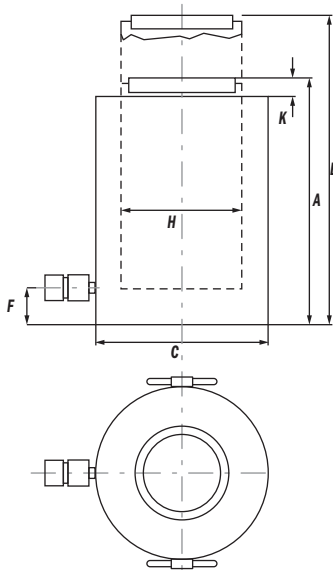

Order No.		A in.	B in.	C in.	Product Wt. lbs.
2000824	RC740*L, RC965*L	11.4	5.5	3.9	158.7
2000825	RC1220*L	12.7	6.9	4.9	249.1

Cyl. Cap. (tons)	Stroke (in.)	Order No.	Oil Cap. (Cu. in.)	A Retracted Height (in.)	B Extended Height (in.)	C Outside Dia. (in.)	F Base to Port (in.)	H Piston Rod Dia. (in.)	K Piston Rod protrusion (in.)	Bore Dia. (in.)	Cyl. Effective Area (in.)	Tons @ 10,000 psi	Product Wt. (lbs)
740	2.0	RC7402L	293.6	15.6	17.6	18.7	3.5	TR13.8X6	0.2	13.8	149.1	742	1,202
740	6.0	RC7406L	880.7	19.5	25.4	18.7	3.5	TR13.8X6	0.2	13.8	149.1	742	1,506
740	10.0	RC74010L	1,467.8	23.4	33.2	18.7	3.5	TR13.8X6	0.2	13.8	149.1	742	1,810
965	2.0	RC9652L	383.2	17.9	19.9	21.3	3.9	TR15.7X6	0.2	15.7	194.8	970	1,574
962	6.0	RC9656L	1,150.2	21.9	27.8	21.3	3.9	TR15.7X6	0.2	15.7	194.8	970	2,183
962	10.0	RC96510L	1,916.2	25.8	35.6	21.3	3.9	TR15.7X6	0.2	15.7	194.8	970	2,579
1220	2.0	RC12202L	485.1	17.4	19.4	23.6	4.3	TR17.7X6	0.2	17.7	246.5	1227	2,136
1220	6.0	RC12206L	1,455.8	23.5	29.4	23.6	4.3	TR17.7X6	0.2	17.7	246.5	1227	2,888
1220	10.0	RC122010L	2,452.2	27.5	37.3	23.6	4.3	TR17.7X6	0.2	17.7	246.5	1227	3,373

ACCESSORIES

C Series

Mounting accessories



CYLINDERS



Threaded Connector

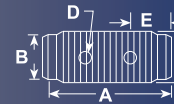

Cylinder Tons	Part No.	A	B	C	D	E
5	25748	1 ³ / ₄	7/8 Dia.	3/4 — 14 NPSM	3/16 Dia.	1/2
10	25664	1 ⁵ / ₈	1 ⁷ / ₁₆ Dia.	1 ¹ / ₄ — 11 ¹ / ₂ NPSM	5/16 Dia.	9/16
25	25654	2 ¹ / ₄	2 ¹ / ₈ Dia.	2 — 11 ¹ / ₂ NPSM	3/8 Dia.	5/8



Piston Clevis

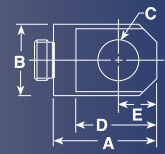

Cylinder Tons	Part No.	A	B	C	D	E	F
5	350095	1 ³ / ₄	1 ¹ / ₈	5/8	17/16	5/8	3/4-16
10 or 15*	350094	2 ⁹ / ₁₆	1 ¹¹ / ₁₆	7/8	2 ⁵ / ₁₆	1	1-8
25**	420059	2 ¹⁵ / ₁₆	2 ¹ / ₄	1 ¹ / ₄	2 ¹¹ / ₁₆	1 ¹ / ₄	1 ¹ / ₂ -16

* Can be used with RD106, RD1010 Cylinder.

** RD256 & RD2514

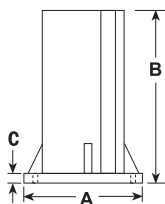

Support Base

Cylinder	Order	A	B	C
10	420062	7	5	7/16
25	420063	7	5	7/16



Threaded Adapter Plain Adapter

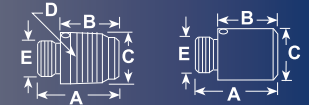

Cylinder Tons	Part No.	A	B	C	D	E
5	202178 (threaded)	1 ⁵ / ₈	1 ¹ / ₈	1 ¹ / ₁₆ Dia.	3/4 — 14 NPT	3/4 — 16 UNF-2A
10 or 15	202179 (threaded)	1 ¹³ / ₁₆	1 ¹ / ₁₆	1 ⁵ / ₈ Dia.	1 ¹ / ₄ — 11 ¹ / ₂ NPT	1 — 8 UNC-2A
25	202180 (threaded)	2 ³ / ₄	1 ⁷ / ₈	2 ³ / ₈ Dia.	2 — 11 ¹ / ₂ NPT	1 ¹ / ₂ — 16 UN-2A
10 or 15	350724 (plain)	2	1 ¹ / ₄	1 ³¹ / ₆₄ Dia.	—	1 — 8 UNC-2A
25	350723 (plain)	2 ¹ / ₈	1 ¹ / ₄	2 ¹ / ₄ Dia.	—	1 ¹ / ₂ — 16 UN-2A

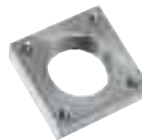

Cylinder Mounting Plate

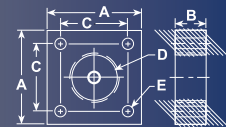

Cylinder Tons	Part No.	A	B	C	D	E
5	350099	3	1	2 ¹ / ₈	1 ¹ / ₂ — 16 UN-2B	1 ¹¹ / ₃₂
10	350100	3 ¹ / ₂	1	2 ⁵ / ₈	2 ¹ / ₄ — 14 UNS-2B	1 ¹¹ / ₃₂
15	350184	3 ¹ / ₂	1	2 ⁵ / ₈	2 ³ / ₄ — 16 UN-2B	1 ¹¹ / ₃₂
25	420064	5	2	3 ²¹ / ₃₂	3 ⁵ / ₁₆ — 12 UN-2B	2 ¹ / ₃₂

Extension Rod

Cylinder Tons	Part No.	A	B	C	D	E
5	350895	5	7/8 Dia.	3/4 — 14 NPT	21/64 Dia.	2
5	38908	10	7/8 Dia.	3/4 — 14 NPT	21/64 Dia.	2
5	350896	18	7/8 Dia.	3/4 — 14 NPT	21/64 Dia.	2
10	350897	5	17/16 Dia.	1 1/4 — 11 1/2 NPT	21/64 Dia.	2
10	38909	10	17/16 Dia.	1 1/4 — 11 1/2 NPT	21/64 Dia.	2
10	350898	18	17/16 Dia.	1 1/4 — 11 1/2 NPT	21/64 Dia.	2

Cylinder Base Attachment

Cylinder Tons	Part No.	A	B	C	D
5	208380	1 5/8	1 3/4 Dia.	3/4 14 NPSM	9/32 Dia. (2) 1/4 — 20 UNC x 3/4 Lg. Socket Head Cap Screws
10	208381	1 7/8	2 1/2 Dia.	1 1/4 — 11 1/2 NPSM	1 1/32 Dia. (2) 5/16 — 18 UNC x 3/4 Lg. Socket Head Cap Screws
25	208382	2 3/8	3 3/8 Dia.	2 — 11 1/2 NPSM	1 7/32 Dia. (2) 1/2 — 13 UNC x 1 Lg. Socket Head Cap Screws

Cylinder Flat Base

Cylinder Tons	Part No.	A	B	C	D
5	25750 *	4 1/2	2 1/2	3/4 — 14 NPSM	1 11/32
10	32325 *	6 9/16	3 1/2	1 1/4 — 11 1/2 NPSM	1 7/16

Smooth Saddle Serrated Saddle

Cylinder Tons	Part No.	A	B	C
5	25746 * (serrated)	1 1/8	1 5/16 Dia.	3/4 — 14 NPSM
10 or 15	31772 * (serrated)	1 1/8	2 Dia.	1 1/4 — 11 1/2 NPSM
25	31776 * (serrated)	1 5/16	3 Dia.	2 — 11 1/2 NPSM
5	351575 * (plain)	1 1/8	1 5/16 Dia.	3/4 — 14 NPSM
10	24016 * (plain)	1 1/8	2 Dia.	1 1/4 — 11 1/2 NPSM
25	351576 * (plain)	1 5/16	3 Dia.	2 — 11 1/2 NPSM

Body Clevis†

Cylinder Tons	Part No.	A	B	C	D	E	F
5	350096	2 1/16	1 1/8	5/8	5/8	9/16	1/4
10	350097	3	1 11/16	7/8	1	1	1/4
15	350098	3 1/16	1 11/16	7/8	1	1	1/4
25	420061	3 9/16	2 1/4	1 1/4	1 1/4	1 1/2	1/4

Swivel Cap

Cylinder Tons	Part No.	A	B
10 or 15	350144	7/8	1 3/8
25	350145	1 1/8	2
55 or 75	350376	1 1/4	2 13/16
100	351574	1 29/32	3 15/32

90° "V" Base

Cylinder Tons	Part No.	A	B	C
5	25388 * 1 3/8	1 1/16	3/4 — 14 NPSM	
10	25395 * 2 1/8	2 1/8	1 1/4 — 11 1/2 NPSM	

Plunger Base

Cylinder Tons	Part No.	A	B	C
25	25652	6	1 1/4	2 — 11 1/2 NPSM

* Items require threaded adapter (Page 36) when used with "C" series cylinders. They may be used on threaded "CBT" cylinders without the use of an adapter.
 † Mounting screws are included.



ACCESSORIES

Swivel Caps Center Hole Accessories

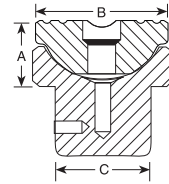
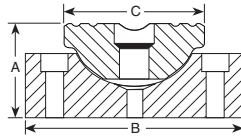

CYLINDERS

Use with Cyl. No.		Swivel Cap Order No.	Wt. (lbs.)	A (in.)	B (in.)	C (in.)
RSS101		350320	0.5	1	1 ⁷ / ₁₆	1 ⁷ / ₁₆
RSS202		350321	1.3	1 ³ / ₈	2 ¹ / ₈	2 ¹ / ₈
RSS302		350322	1.6	1 ³ / ₈	2 ¹ / ₂	2 ¹ / ₈
RSS502		350331	2.7	1 ⁷ / ₁₆	3 ¹ / ₄	2 ¹ / ₈
RSS1002		350332	6.6	1 ¹³ / ₁₆	4 ³ / ₈	3 ³ / ₈
Tonnage		"RA" CYLINDERS				
55		350376	2	1 ¹ / ₄	2 ¹³ / ₁₆	2 ¹³ / ₁₆
100		350984	5.6	1 ¹⁵ / ₁₆	3 ¹ / ₈	3 ³ / ₄

SWIVEL CAPS FOR "RD" CYLINDERS						
Cylinder Tonnage	Swivel Cap Order No.	Prod. Wt. (lbs.)	A (in.)	B (in.)	C (in.)	
10	350144	0.8	7/8	1 ⁷ / ₁₆	5 ⁵ / ₆₄	
25	350145	1.3	1 ¹ / ₈	2 ¹ / ₈	1 ⁷ / ₁₆	
55	351325	4.2	2 ⁷ / ₁₆	2 ¹ / ₂	1 ³⁵ / ₆₄	
100	351324	11.2	2 ⁶¹ / ₆₄	3 ³ / ₄	2 ²¹ / ₃₂	
150	351334	12.8	2 ⁵ / ₈	4 ³ / ₈	3 ¹ / ₁₆	

For use with "RC" cylinders			SWIVEL CAPS Reduce the effects of off center loading. Tilts up to 5 degrees. Radial grooves on top of cap reduce load slippage.				For use with "RL" cylinders		
Use with Cyl. No.	Swivel Cap Order No.	Wt. (lbs.)	A (in.)	B (in.)	A (in.)	B (in.)	Use with Cyl. No.	Swivel Cap Order No.	Wt. (lbs.)
150-200 ton	420867	8.8	1 ¹ / ₂	5 ¹ / ₈	1	2 ¹³ / ₁₆	55-100 ton	420866	1.8
280 ton	420868	13.5	1 ³ / ₄	5 ⁷ / ₈	1 ¹ / ₂	5 ¹ / ₈	150-200 ton	420867	8.8
355 ton	420869	37	2 ³ / ₄	7 ¹¹ / ₁₆	1 ³ / ₄	5 ⁷ / ₈	280 ton	420868	13.5
430 ton	420870	52	3 ¹ / ₈	8 ⁷ / ₈	2 ³ / ₄	7 ¹¹ / ₁₆	355 ton	420869	37
565 ton	420871	78	3 ⁵ / ₈	9 ⁷ / ₈	3 ¹ / ₈	8 ⁷ / ₈	430 ton	420870	52
					3 ⁵ / ₈	9 ⁷ / ₈	565 ton	420871	78

Reduce the effects of off-center loading. Tilts up to 5 degrees. Radial grooves on top of cap reduce load slippage. Notch across face of each cap helps keep loads having a protruding or round shaped centered.

"CENTER-HOLE" CYLINDER ACCESSORIES				
To use with Cyl. No.	RT172, RH203	RT302, RH302, RH303, RH306	RT503, RH503, RH603, RH605, RH606	RT1004
Order Set No.	RHA20	RHA30	RHA50	RHA100
1 Speed Crank	24814	27198	29595	303785
2 Speed Nut	302482	302483	33439	34136
3 Adjusting Screw	1"-8 thd.	1 ¹ / ₄ "-7 thd.	1 ⁵ / ₈ "-5 ¹ / ₂ thd.	2 ¹ / ₂ "-8 thd.
4 Threaded Insert	Order threaded insert for RH series cylinders with the accessory set. (See page 39). Threaded insert supplied with RT series cylinders			
5 Pushing Adapter	201923	34510	34755	—
	1"-8 thd. 1/2" dia. shank	1 ¹ / ₄ "-7 thd. 3/4" dia. shank	1 ⁵ / ₈ "-5 ¹ / ₂ thd. 1" dia. shank	
6 Pushing Adapter	201454	34511	34756	—
	1"-8 thd. 3/4" dia. shank	1 ¹ / ₄ "-7 thd. 1" dia. shank	1 ⁵ / ₈ "-5 ¹ / ₂ thd. 1 ¹ / ₄ " dia. shank	
7 Jack Screw	24813	25931	32701	32702
	1"-8 thd. 7" lg.	1 ¹ / ₄ "-7 thd. 9" lg.	1 ⁵ / ₈ "-5 ¹ / ₂ thd. 11" lg.	2 ¹ / ₂ "-8 thd. 16" lg.
8 Screw Cap	28228	28229	28230	—
	1"-8 thd. 1 ¹ / ₂ " dia.	1 ¹ / ₄ "-7 thd. 1 ³ / ₄ " dia.	1 ⁵ / ₈ "-5 ¹ / ₂ thd. 2 ¹ / ₄ " dia.	

ACCESSORIES

Seal Kits

Cylinder Order No.	Seal Kit*	Viton Seal Kit
C51C	300404	300210
C53C	300404	300210
C55C	300404	300210
C57C	300404	300210
C59C	300404	300210
C101C	300116	300211
C102C	300116	300211
C104C	300116	300211
C106C	300116	300211
C108C	300116	300211
C1010C	300116	300211
C1012C	300116	300211
C1014C	300116	300211
C1016C	300116	300211
C151C	300453	300471
C152C	300453	300471
C154C	300453	300471
C156C	300453	300471
C158C	300453	300471
C1510C	300453	300471
C1512C	300453	300471
C1514C	300453	300471
C1516C	300453	300471
C251C	300147	300213
C252C	300147	300213
C254C	300147	300213
C256C	300147	300213
C258C	300147	300213
C2510C	300147	300213
C2512C	300147	300213
C2514C	300147	300213
C552C	300114	300215
C554C	300114	300215
C556C	300114	300215
C5510C	300114	300215
C5513C	300114	300215
C756C	300647	300846
C7513C	300647	300846
C1002C	300112	300216
C1006C	300112	300216
C10010C	300112	300216
C55CBT	300404	300210
C106CBT	300116	300211
C1010CBT	300116	300211
C256CBT	300147	300213
C2514CBT	300147	300213
R1502C	300676	—
R1506C	300676	—
R15010C	300676	—
R2002C	300677	—
R2006C	300677	—

Cylinder Order No.	Seal Kit*	Viton Seal Kit
R20010C	300677	—
R2802C	300678	—
R2806C	300678	—
R28010C	300678	—
R3552C	300679	—
R3556C	300679	—
R35510C	300679	—
R4302C	300680	—
R4306C	300680	—
R43010C	300680	—
R5652C	300681	—
R5656C	300681	—
R56510C	300681	—
R1002D	300928	—
R1006D	300928	—
R10010D	300928	—
R1502D	300929	—
R1506D	300929	—
R15010D	300929	—
R2002D	300930	—
R2006D	300930	—
R20010D	300930	—
R2802D	300931	—
R2806D	300931	—
R28010D	300931	—
R3552D	300932	—
R3556D	300932	—
R35510D	300932	—
R4302D	301047	—
R4306D	301047	—
R43010D	301047	—
R5652D	300934	—
R5656D	300934	—
R56510D	300934	—
R552L	300674	—
R556L	300674	—
R5510L	300674	—
R1002L	300675	—
R1006L	300675	—
R10010L	300675	—
R1502L	300676	—
R1506L	300676	—
R15010L	300676	—
R2002L	300677	—
R2006L	300677	—
R20010L	300677	—
R2802L	300678	—
R2806L	300678	—
R28010L	300678	—
R3552L	300679	—
R3556L	300679	—

Cylinder Order No.	Seal Kit*	Viton Seal Kit
R35510L	300679	—
R4302L	300680	—
R4306L	300680	—
R43010L	300680	—
R5652L	300681	—
R5656L	300681	—
R56510L	300681	—
RA202	300631	—
RA204	300631	—
RA206	300631	—
RA302	300632	—
RA304	300632	—
RA306	300632	—
RA552	300391	—
RA554	300391	—
RA556	300391	—
RA5510	300391	—
RA1002	300444	—
RA1006	300444	—
RA556L	300395	—
RA1006L	300396	—
RD106	300017	—
RD1010	300017	—
RD256	300118	—
RD2514	300118	—
RD556	300005	—
RD5513	300005	—
RD5518	300005	—
RD8013	300410	—
RD1006	300006	—
RD10013	300006	—
RD10020	300006	—
RD1506	300007	—
RD15013	300007	—
RD15018	300007	—
RD2006	300008	—
RD20013	300008	—
RD3006	300466	—
RD30013	300466	—
RD4006	300467	—
RD40013	300467	—
RD5006	300468	—
RD50013	300468	—
RH102	300071	300221
RH108	300071	300221
RH120	300657	—

Cylinder Order No.	Seal Kit*	Viton Seal Kit
RH121	300576	—
RH121T	300576	—
RH123	300576	—
RH202	300615	—
RH203	300069	300222
RH206	300615	—
RH302	300037	300223
RH306	300037	300223
RH503	300059	300225
RH603	300477	300476
RH606	300477	300476
RH1003	300485	300585
RH303	300077	300224
RH306D	300822	300224
RH3010	300625	—
RH605	300269	300226
RH6010	300626	—
RH1001	300927	—
RH1006	300295	300227
RH10010	300629	—
RH1505	300154	300228
RH1508	300583	—
RH2008	300582	—
RHA306	300867	300868
RHA604D	300269	300226
RLS50	300454	—
RLS100	300455	—
RLS200	300456	—
RLS300	300457	—
RLS500S	300458	—
RLS750S	300459	—
RLS1000S	300460	—
RLS1500S	300461	—
RP25	300628	—
RP55	300627	—
RSS101	300010	—
RSS202	300011	—
RSS302	300297	—
RSS502	300292	—
RSS1002	300293	—
RSS2503	—	—
RSS1002D	300578	—
RT172	300358	—
RT302	300359	—
RT503	300360	—
RT1004	300024	—



CYLINDERS

ACCESSORIES

Cribbing Blocks



CYLINDERS

Convert Power Team “Shorty” cylinders to mechanical cribbing devices; more stable than timber or other awkward, makeshift methods. Ideal for lifting applications such as structure moving. Reduces cribbing time dramatically. In effect, increases the stroke of the cylinder; stacking pads act as cylinder extensions:

1. Extend cylinder and insert lower supporting ring.
2. Retract cylinder, insert a stacking pad.
3. Extend cylinder again; pad increases cylinder stroke.
4. Repeat process until all rings and pads are used.

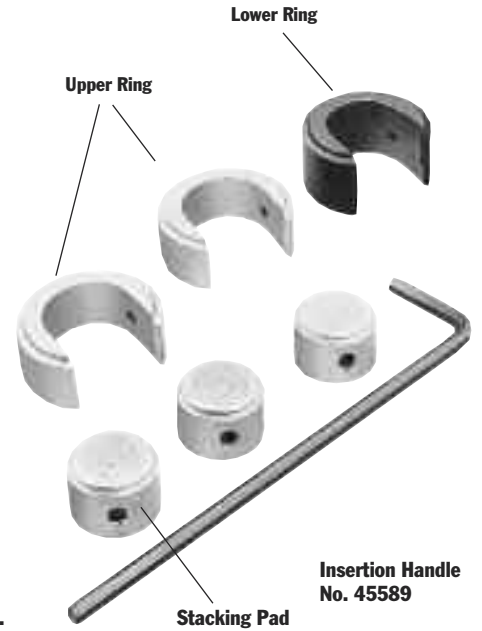

Each cribbing block set includes rings, pads and insertion handle.

- No. CB30** — Cribbing block set for use with No. RSS302; 30 ton cylinder.
- No. CB50** — Cribbing block set for use with No. RSS502; 50 ton cylinder.
- No. CB100** — Cribbing block set for use with No. RSS1002; 100 ton cylinder.
- No. 45589** — Insertion handle is used for inserting rings and pads.

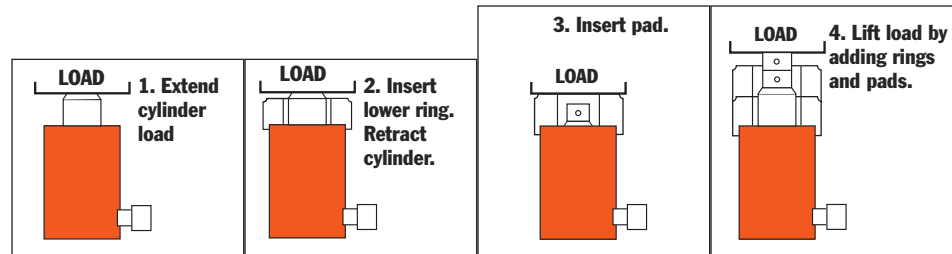

FOR USE WITH ORDER NUMBER	30 TON CYLINDER NO. RSS302 30 TON SET NO. CB30			50 TON CYLINDER NO. RSS502 50 TON SET NO. CB50			100 TON CYLINDER NO. RSS1002 100 TON SET NO. CB100		
	Lower Ring	Upper Ring	Stacking Pad	Lower Ring	Upper Ring	Stacking Pad	Lower Ring	Upper Ring	Stacking Pad
No. included in set	1	2	3	1	2	3	1	3	4
Outside Diameter (in.)	4 ¹ / ₂	4 ¹ / ₂	2 ³ / ₄	5 ¹ / ₂	5 ¹ / ₂	3 ³ / ₈	7 ²⁵ / ₆₄	7 ²⁵ / ₆₄	4 ³ / ₄
Inside Diameter (in.)	2 ¹³ / ₁₆	2 ¹³ / ₁₆	—	3 ²⁹ / ₆₄	3 ²⁹ / ₆₄	—	4 ¹³ / ₁₆	4 ¹³ / ₁₆	—
Height, each (in.)	2 ⁹ / ₃₂	1 ⁵¹ / ₆₄	1 ²⁵ / ₃₂	2 ⁷ / ₃₂	1 ²³ / ₃₂	1 ¹¹ / ₁₆	2 ¹ / ₈	1 ³ / ₄	1 ²³ / ₃₂
Total stacked height of rings in Set (in.)		5 ⁷ / ₁₆			5 ³ / ₁₆			6 ⁷ / ₈	
Weight of Set (lbs.)		20			28			64	

Each set includes one Insertion Handle No. 45589 - 1/2" Hex. x 18" Long, 4" Bend



CYLINDER LIFTING HANDLE

No. 420655OR9	—	Lifting handle for “C” series, 25 ton cylinders.
No. 421312OR9	—	Lifting handle for RH302, RH303, RH306 and RH306D, cylinders.
No. 252215	—	Lifting handle RHA306, 30 ton cylinder.
No. 420496BK2	—	Lifting handle RA552 and RA554, 55 ton cylinders.
No. 420498BK2	—	Lifting handle RA1002, 100 ton cylinder.



ALUMINUM CYLINDER BASE

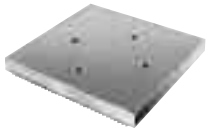

Aluminum Cylinder Base – For use when an enlarged cylinder base is needed or advantageous. Attaches to bottom of RA556, RA556L and RA5510 with four 3/8"-16 screws (included). Serrated base for extra stability.

No. 208406 – Aluminum cylinder base, 7" square. For use with RA556, RA556L and RA5510 cylinders.



HEAD INSERTS FOR RH SERIES CYLINDERS

For Use With:	Threaded Insert Order No.
RH102, RH108	28632 3/4"-16
RH203	28612 1"-8
RH302, RH306	38904 1 1/4"-7
RH303	28644 1 1/4"-7
RH503	38855 1 5/8"-5 1/2
RH603, RH605 RH606	34251 1 5/8"-5 1/2



Quick-Change Inserts

"QUICK CHANGE" HEAD INSERTS FOR RT SERIES CYLINDERS

For Use With:	Threaded Order No.*	Plain Order No.
RT172	21669	21714
RT302	21873	21872
RT503	22274	22275
RT1004	24197	24196

Switch from a tapped hole to a plain hole quickly with these cylinder head inserts. They are held in place with a socket screw. Plain hole permits use of a speed nut for readjusting cylinder after extension.

* Provided with cylinder