

SHOP

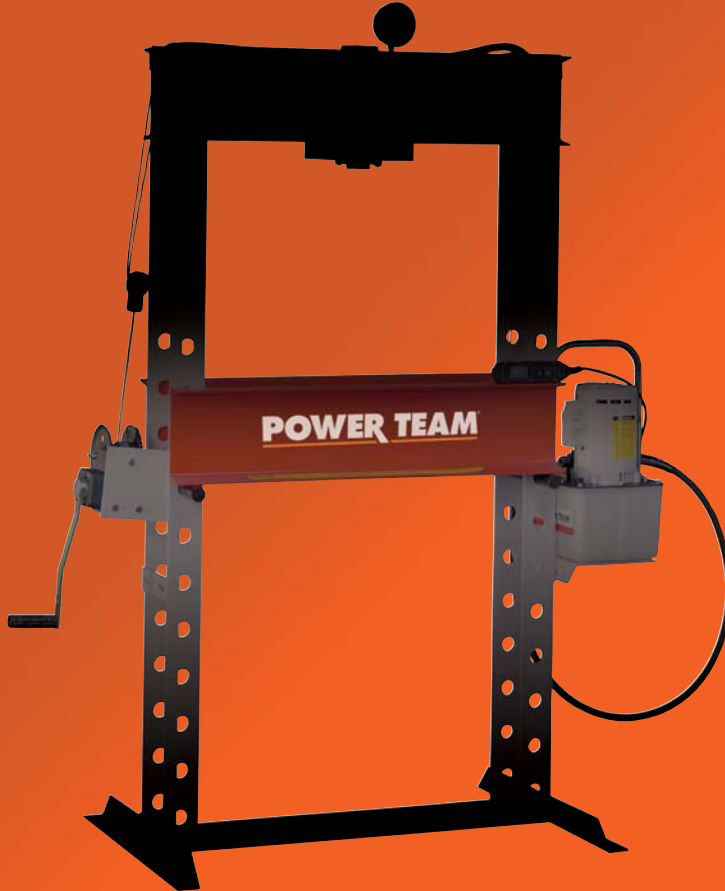

SHOP EQUIPMENT

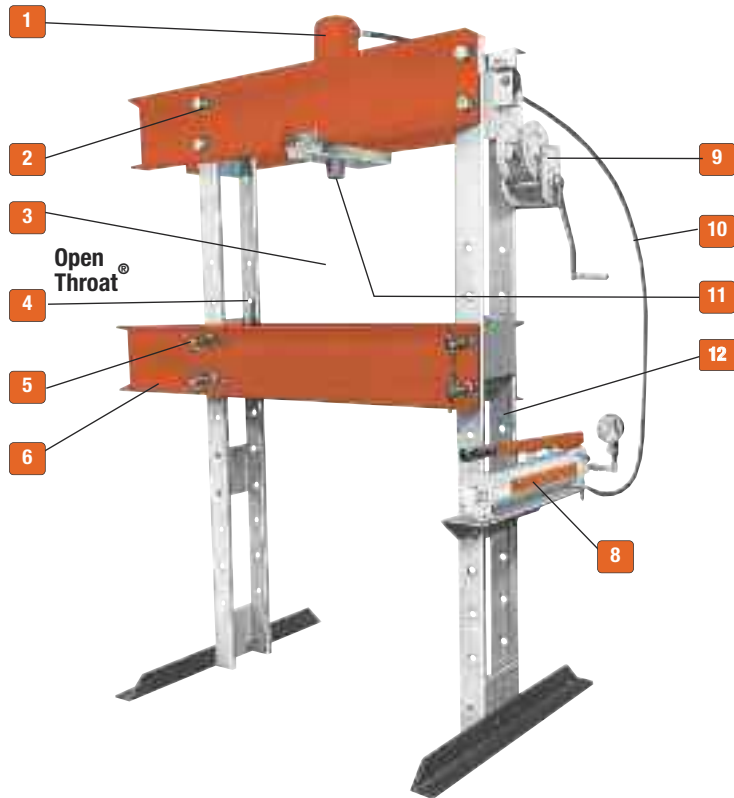

THE UNIQUE BENEFITS OF THE POWER TEAM PRESS

1 2 TO 1 SAFETY FACTOR on hydraulic cylinders and they meet ASME B30.1 standards. Cylinders are easily removed for other applications. Single- or double-acting cylinders are available; built-in relief valve on double-acting cylinders.

2 FULL RATED CAPACITY across width of upper frame, even with workhead moved to one side. (Heavy-duty presses only.)

3 LARGER WORK AREA than most competitors' models.

4 ALIGNMENT LEVER for simple pin replacement after raising or lowering the bed.

5 CLOSE MANUFACTURING TOLERANCE allows even load distribution over four alloy steel pins; not two, like some competitors. (Heavy-duty presses only.)

6 OPEN THROAT® FEATURE on 25 ton press provides additional work area by

mounting cylinder on outside for C-frame advantage.

7 FRAMES CAN BE USED HORIZONTALLY for pressing jobs on extra-long shafts (see photo on next page).

8 ELECTRIC, AIR OR HAND HYDRAULIC PUMPS are available. All are standard Power Team pumps.

CSA approved electric pumps are standard on all presses. Externally adjustable relief valve for precise operator control of working pressure

is standard on all electric pumps except PE10 and PE17 series.

24 volt hand switch for remote control on pumps equipped with solenoid valves.

9 ONE-MAN OPERATION for bed adjustment. Winch unit quickly raises or lowers bed to desired height. Self-locking winch mechanism prevents bed from dropping when handle is released.



Horizontal pressing capabilities

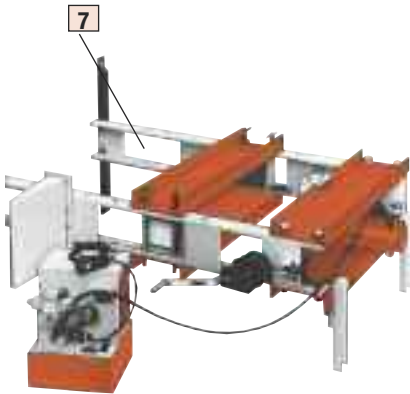

Page
C FRAME ... 136

Page
H FRAME ... 137
25-55 TON

Page
H FRAME ... 140
100-200 TON

Page
H FRAME ... 142
80-200 TON
ROLL BED

Page
ACCESSORIES ... 144



Page
FLOOR CRANES ... 146



Page
LOAD-ROTORS® ... 147

10 3/8" I.D. HOSE on spring return cylinders on heavy-duty presses provides up to six times faster cylinder return than standard 1/4" I.D. hose.

11 FAST CYLINDER APPROACH to work provided by 2-speed hand, air or electric pumps.

12 RUGGED UPRIGHTS, 50 percent stronger than channel iron. Four post design means open side for easy loading of long material.

NOTE: Certain features do not apply to Power Team 10 ton, Roll-Bed, or economy presses.

NOTE: Certain press applications may require guarding. Because of the multitude of possible press uses, it is impossible to design a guard that will meet every customer need. The end user must provide their own guarding where the situations dictate.

IMPORTANT SAFETY INFORMATION:

Power Team has protective blankets available which may afford protection from injury to users and others should part breakage occur. Power Team recommends the use of these blankets for all pushing, pulling, pressing, and lifting applications. See page 209 for additional information.

SHOP PRESS

C Frame

25 Tons Press

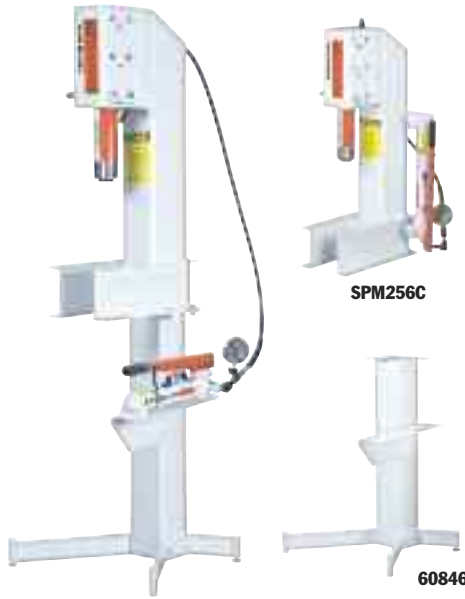

- Can be bench mounted or on optional pedestal base.
- Bench mount requires less than 1.5 sq. ft. of space; on optional pedestal, only 4 sq. ft. of floor space is needed.
- “Open Throat” design makes loading and unloading of work easy.
- Cylinder head adjusts to three convenient working positions, providing up to 20¹/₄” of “daylight.”
- Hydraulic cylinder delivers a 6¹/₄” stroke, is driven by a P59 two-speed hand pump.

Pedestal Base No. 60846 – Provides a stable base for SPM256C. Includes a bracket for mounting the pump on the side of pedestal press. Wt., 76 lbs.

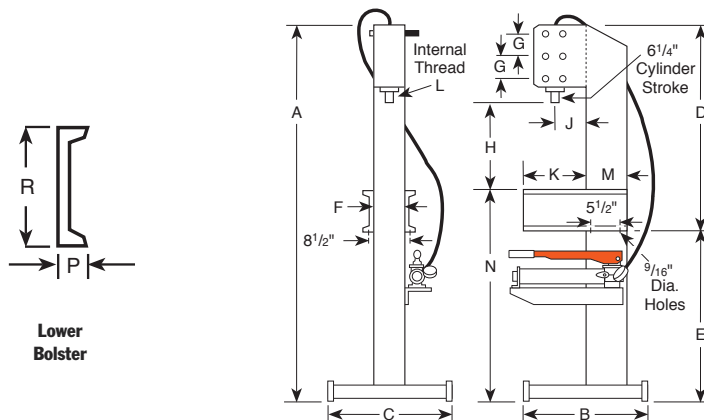

DIMENSIONS

A	B	C	D	E	F	G	H (Cyl. Retracted)	J	K	L	M	N	P	R	Floor Space
(in)	(in.)	(in.)	(in.)	(in.)	(in.)	(in.)	(in.)	(in.)	(in.)	(in.)	(in.)	(in.)	(in.)	(in.)	(in.)
77 ⁵ / ₈	24 ¹ / ₂	24	41 ⁵ / ₈	36	6	5	10 ³ / ₄ , 15 ¹ / ₄ , 20 ³ / ₄	6 ¹ / ₂	12 ¹ / ₂	1 ¹ / ₂ – 16	8	43	2	7	24 x 24 ¹ / ₂

ORDERING INFORMATION

Capacity (tons)	Type Cyl. Used	Stroke	Cyl. Model	Order No.	Speed** Advance	Pressing	Type Pump	Pump Model	Prod.Wt. (lbs.)
25	Single-Acting	6 ¹ / ₄ ”	C256C	SPM256C*	.129 in./stroke	.03 in./stroke	Hand	P59	240
25	Single-Acting	6 ¹ / ₄ ”	C256C	SPX256C*	.129 in./stroke	.03 in./stroke	—	—	240

* SPM256C does not include No. 60846 pedestal base. Pump not included.

** Typical performance based on pump specifications. Actual speeds may vary with operating conditions.

SHOP PRESS

H Frame

10 Tons Bench/Floor Press

- Ideal for small pressing jobs; repairing small motors, armatures, removing and installing gears, bearings, other press-fit parts.
- Bench press has 15³/₈" x 18" work area; floor press bed height is adjustable from 5" to 41" with horizontal "daylight" of 21".
- Choices of power sources: single-speed hand pump, electric/hydraulic or air/hydraulic.
- Hydraulic gauges, hoses and fittings included.

PUMP ELECTRICAL SPECIFICATIONS

PE10 Series – 1/4 hp, 115 volt, 60 cycle, single phase. Also available in 230 volt, 50 cycle, add suffix "-220" to order number.



SP1010A

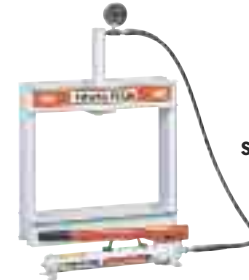

SPM1010

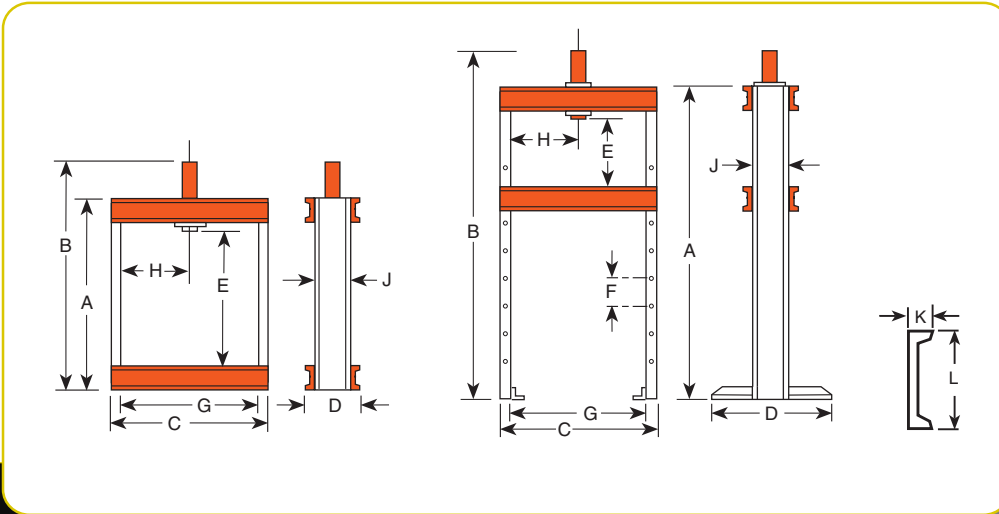

DIMENSIONS

	A (in)	B (in.)	C (in.)	D (in.)	E (in.)	F (in.)	G (in.)	H (in.)	J (in.)	K (in.)	L (in.)	Bench Space (in.)	Floor Space (in.)
Bench	24 ¹ / ₂	33 ¹ / ₈	25 ¹ / ₄	7 ³ / ₁₆	15 ³ / ₈	—	22	11	4	1 ⁹ / ₁₆	4	7 ³ / ₁₆ X 25 ¹ / ₄	—
Floor	59	67 ⁵ / ₈	25 ¹ / ₄	28	5-41	6	22	2 ¹ / ₂ -18 ¹ / ₂ *	4	1 ⁹ / ₁₆	4	—	28 X 28 ¹ / ₄

*Lateral head movement

ORDERING INFORMATION

Frame	Cap. (tons)	Type of Cyl. Used	Stroke	Cylinder Model	Order No.	Speed (in./min.)††† Advance Pressing	Type Pump	Pump Model †	Prod. Wt. (lbs.)
222481 Bench	10	Single-Acting	10 ¹ / ₈ "	C1010C	SPM1010	.06 in./stroke	Hand	P55	91
222480 Floor	10	Single-Acting	10 ¹ / ₈ "	C1010C	SPH1010	.06 in./stroke	Hand	P55	171
222480 Floor	10	Single-Acting	10 ¹ / ₈ "	C1010C	SPE1010	0.2 2.2	Elec. ††	PE102	175
222480 Floor	10	Single-Acting	10 ¹ / ₈ "	C1010C	SP1010A	0.3 3.7	Air	PA9H	162
222480 Floor	10	Double-Acting	10"	RD1010	SPE1010D	0.2 2.2	Elec. ††	PE104	192

† Optional air/hydraulic pumps available on request.

†† "Advance" position holds pressure with motor shut off. "Return" position advances cylinder with motor running and returns cylinder with motor shut off.

††† Typical performance based on 100 psi and 10,000 psi pump specifications. Actual speeds may vary with operating conditions.

PRESS

H Frame

Open Throat & Economy Press
25 Ton Presses

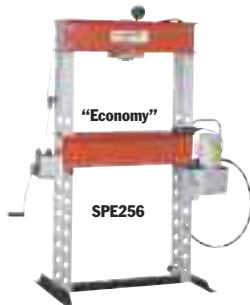

Hydraulic gauge and hydraulic fittings are included with presses.

OPEN THROAT PRESSES

- Design permits use as both “H” frame and “C” frame press; cylinder can be mounted on frame extension to handle jobs which won't fit between uprights.
- Open throat press models are also available with remote control to enable the operator to view work from all sides with fingertip control of cylinder piston travel.
- Off-center pressing loads of full capacity can be applied across entire width of frame.

ECONOMY PRESSES

- Rugged, yet reasonably priced. Handles many “big press” tasks, and perfect for many of the “in-between” jobs you see almost daily. (Note: stroke length limited to 6¹/₄” on economy models.)

FEATURES OF BOTH OPEN THROAT AND ECONOMY PRESSES

- Press bed height easily adjustable with winch. Bed will not drop when handle is released.
- Choice of power sources for rapid cylinder advance: two-speed hydraulic hand pump, electric/hydraulic or air/hydraulic.

PUMP ELECTRICAL SPECIFICATIONS

PE17 Series – 1/2 hp, 115 volt, 60 cycle, single phase.

PE21 Series – 1 hp, 115 volt, 60 cycle, single phase. Both pumps available in 230 volt, 50 cycle, add suffix “-220” to order no.

Open Throat feature enables cylinder to be mounted on outside of press frame for fast bearing removal and more.

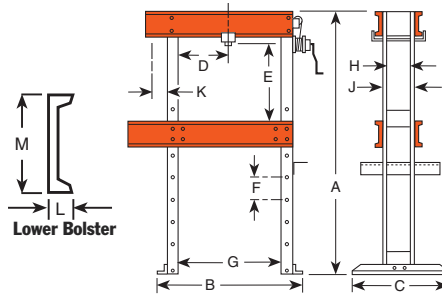

DIMENSIONS

A (in.)	B (in.)	C (in.)	D* (in.)	E (in.)	F (in.)	G (in.)	H (in.)	J (in.)	K (in.)	L (in.)	M (in.)	Floor Space (in.)
68	43	28	3 - 29	6 ⁷ / ₈ - 43 ³ / ₈	4 ¹ / ₂	32	5 ¹ / ₂	6 ¹ / ₂	7	2 ¹ / ₂	8	43 x 28

*Lateral head movement

ORDERING INFORMATION

Cap. (tons)	Type of Cylinder Used	Stroke	Cylinder Model	Order No.	Speed (in./min.)†††	Type Pump	Valve Type	Pump‡ Model	Prod.Wt. (lbs.)
					Advance	Pressing			
“Open Throat” presses									
25	Single-Acting	14 ¹ / ₄ ”	C2514C	SPA2514	9.8	1.2	Air	PA6	683
25	Single-Acting	14 ¹ / ₄ ”	C2514C	SPM2514	.49	.03	Hand	P159	693
					in./stroke	in./stroke	Release		
25	Single-Acting	14 ¹ / ₄ ”	C2514C	SPE2514	46.6	3.3	Elec.	PE172	665
25	Single-Acting	14 ¹ / ₄ ”	C2514C	SPE2514S	52	4.0	Elec.	PE213S	759
25	Double-Acting	14 ¹ / ₄ ”	RD2514	SPE2514DS	52	4.0	Elec.	PE214S	787
“Economy” presses									
25	Single-Acting	6 ¹ / ₄ ”	C256C	SPA256	9.8	1.2	Air	PA6	578
25	Single-Acting	6 ¹ / ₄ ”	C256C	SPM256	.129	.129	Hand	P59	595
					in./stroke	in./stroke	Release		
25	Single-Acting	6 ¹ / ₄ ”	C256C	SPE256	46.6	3.3	Elec.	PE172	607

† Solenoid valve with 24 volt remote control hand switch.

†† Holds pressure with motor shut off. Also has an automatic dump setting. Furnished with a 10' remote motor control.

††† Typical performance based on 100 psi and 10,000 psi pump specifications. Actual speeds may vary under operating conditions.

‡ Pump standard with press. Other Power Team pumps can be substituted. dBA at idle and 10,000 psi: PE172-67/81 dBA; PE21-70 dBA measured at 3 foot distance, all sides.

PRESS

H Frame 55 Ton Presses

- Full off-center pressing at full rated capacity across width of upper frame without buckling or bending.
- Maximum “daylight” is 42" x 36", making positioning of even bulky work pieces easy.
- Height of press bed is easily adjusted with winch; friction brake prevents bed from dropping and handle from spinning upon release.
- Presses with single-acting cylinder offer choice of 2-speed hand operated, electric/hydraulic, or air/hydraulic pump. Models with double-acting cylinder have an electric/hydraulic pump.
- Press models equipped with remote control enable operator to view work from all sides with fingertip control of cylinder piston travel.
- Press can be used horizontally for special applications with user-supplied support legs.



Hydraulic gauge and hydraulic fittings are included with presses.

PUMP ELECTRICAL SPECIFICATIONS

PE17 Series – 1/2 hp, 115 volt, 60 cycle, single phase. Also available in 230 volt, 50 cycle.

PE21 Series – 1 hp, 115 volt, 60 cycle, single phase. Also available in 230 volt, 50 cycle.

PQ60 Series – 2 hp, 230 volt, 60 cycle, single phase. Also available in 230 volt, 50 cycle. To order presses with 230 volt, 50 cycle pumps, add suffix “-220” to order no.

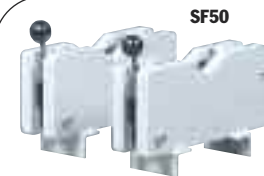

No. SF50 – Straightening fixtures for use with 55-ton shop or 80-ton Roll-Bed® presses (2 ea.). Wt., 104 lbs. **Not part of press, order separately.**

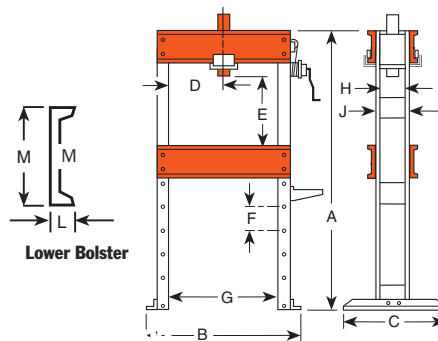

A (in.)	B (in.)	C (in.)	D* (in.)	E (in.)	F (in.)	G (in.)	H (in.)	J (in.)	L (in.)	M (in.)	Floor Space (in.)
72	48 1/2	36	3 1/4-32 3/4	6 - 42	6	36	6 3/4	8	3	12	48 1/2 x 36

*Lateral head movement

ORDERING INFORMATION

Cap. (tons)	Type of Cylinder Used	Stroke	Cylinder Model	Order No.	Speed (in./min.)†††	Type Pump	Valve Type	Pump‡ Model	Prod.Wt. (lbs.)
55	Single-Acting	6 3/4"	C556C	SPA556	4.5	Air	2-Way Foot	PA6	804
55	Single-Acting	6 3/4"	C556C	SPM556	.23	Hand	Load-Release	P159	814
55	Single-Acting	13 3/4"	C5513C	SPM5513	.665	Hand	2-Way	P460	960
55	Single-Acting	6 3/4"	C556C	SPE556	21.7	Elec.	2-Way††	PE172	836
55	Single-Acting	13 3/4"	C5513C	SPE5513	21.7	Elec.	2-Way††	PE172	980
55	Single-Acting	13 3/4"	C5513C	SPE5513S	24.4	Elec.	3-Way†	PE213S	1,056
55	Double-Acting	13 3/8"	RD5513	SPE5513D	21.7	Elec.	4-Way	PE174	993
55	Double-Acting	13 3/8"	RD5513	SPE5513DS	66.1	Elec.	4-Way†	PQ604S	1,114

* Frame is shipped assembled.

† Solenoid valve with 24 volt remote control hand switch.

†† Holds pressure with motor shut off. Also has an automatic dump setting. Furnished with a 10' remote motor control.

††† Typical performance based on 100 psi and 10,000 psi pump specifications. Actual speeds may vary with operating conditions.

‡ Pump standard with press. Other Power Team pumps can be substituted. dBA at idle and 10,000 psi: PE172—67/81; PE21 Series—70; PQ60—74/76; measured at 3 foot distance, all sides.



H FRAME PRESSES

100 Ton Presses

- Cylinder workhead glides across upper frame on rollers, locks in place for off-center pressing jobs. May be used horizontally for special pressing applications with user-supplied supports.
- Press bed is raised and lowered by winch which locks in place for insertion of bed retaining pins. Upper bolster can be lowered 8" for convenient positioning on repetitive jobs.
- Generous "daylight" of 42" x 50" accommodates bulky work pieces, uprights are placed for easy side entry of bars or shafts for straightening or bending.
- Choice of single- or double-acting cylinder. Hydraulic pump options include: 2-speed hand pump with large 2-gallon reservoir, PE172 electric/hydraulic pump or "PQ" series "Quiet" electric/hydraulic pump with low noise level.



Hydraulic gauge and hydraulic fittings are included with presses.



No. SF150 – Straightening fixtures for use with 100-ton shop press and 100-, 150-, and 200-ton Roll-Bed® presses (2 ea.). Wt., 196 lbs. **Not part of press, order separately.**

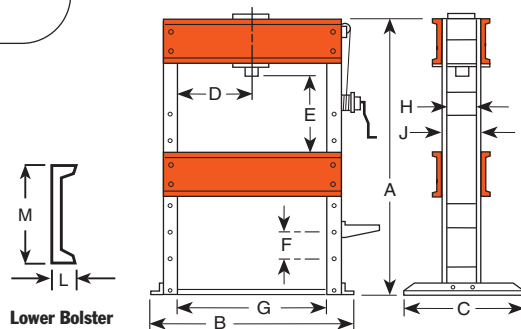

PUMP ELECTRICAL SPECIFICATIONS

PE17 Series – 1/2 hp, 115 volt, 60 cycle, single phase. Also available in 230 volt, 50 cycle, add suffix "-220" to order no.

PQ60 Series – 2 hp, 230 volt, 60 cycle, single phase. Available in 115 volt, 60 cycle and 230 volt, 50 cycle. To order 230 volt, 50 cycle, add suffix "-220" to order no. For 115 volt consult factory.

PQ120 Series – 3 hp, 460 volt, 60 cycle, three phase. Available in 220/380 volt, 50 cycle. To order 380 volt, 50 cycle, add suffix "-380" to order no.

DIMENSIONS

A	B	C	D*	E	F	G	H	J	L	M	Floor Space
(in.)	(in.)	(in.)	(in.)	(in.)	(in.)	(in.)	(in.)	(in.)	(in.)	(in.)	(in.)
77 ¹ / ₄	64	36	7 - 43	2 - 42	8	50	8	10	3 ³ / ₈	15	36 x 78 ¹ / ₄

*Lateral head movement

ORDERING INFORMATION

Cap. (tons)†	Type of Cyl. Used	Stroke	Cylinder Model	Order No.	Speed (in./min.)††	Type Pump	Valve Type	Pump‡ Model	Prod. Wt. (lbs.)	
					Advance	Pressing				
					in./stroke	in./stroke				
100	Single-Acting	10 ³ / ₄ "	C10010C	SPM10010	.356	.01	Hand	3-way	P460	1,698
100	Single-Acting	10 ³ / ₄ "	C10010C	SPE10010	35	2.9	Elec.	3-way	PQ603	1,795
100	Single-Acting	10 ³ / ₄ "	C10010C	SPE10010R	11.5	.8	Elec.	2-way	PE172	1,690
100	Double-Acting	13 ³ / ₈ "	RD10013	SPE10013DS	35	5.8	Elec.	4-way*	PQ1204S	1,886

† Frame is shipped assembled. *Solenoid valve with 24 volt remote control hand switch.
 †† Typical performance based on 100 psi and 10,000 psi pump specifications. Actual speeds may vary under operating conditions.
 ‡ Pump standard with press. Other Power Team pumps can be substituted.
 dBA at idle and 10,000 psi: PE172—67/81; PQ60—74/76; PQ120—73/78. Measured at 3 foot distance, all sides.

H FRAME PRESSES

150-200 Ton Presses

- Standing 7½-feet tall, these giants handle the really big jobs. May be used horizontally for special pressing applications with user-supplied supports.
- Workhead has wide horizontal travel; rugged press frame withstands load of rated capacity across full width of frame.
- Winch mechanism provides easy positioning of press bed, locks in place for insertion of retaining pins. Upper bolster can be lowered 11" for convenient positioning on repetitive jobs.
- Uprights are placed for easy entry of bars or shafts for straightening or bending.
- Fast cylinder approach is provided by PQ1204S "Quiet" electric/hydraulic pump. Has remote control hand switch, enabling operator to view work from all sides with fingertip control of cylinder piston travel.



Hydraulic gauge and hydraulic fittings are included with presses.

PUMP ELECTRICAL SPECIFICATIONS

PQ120 Series – 3 hp, 460 volt, 60 cycle, three phase. Also available in 220/380 volt, 50 cycle, add suffix "-380" to order no. NOTE: To order press with 230 volt, 60 cycle, single phase pump, order press less PQ1204S. Order pump No. PQ604S separately.

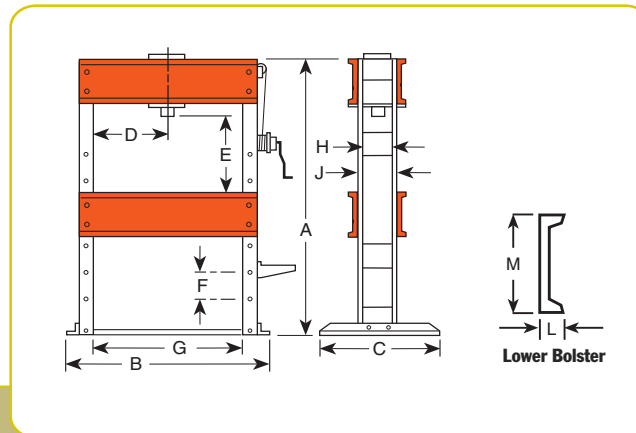

DIMENSIONS

A (in.)	B (in.)	C (in.)	D* (in.)	E (in.)	F (in.)	G (in.)	H (in.)	J (in.)	L (in.)	M (in.)	Floor Space (in.)
90	71	44	11 - 39	9 - 43¾	11	50	12½	15	4⅞	18	44 x 71

*Lateral head movement

ORDERING INFORMATION

Capacity (tons)†	Type of Cylinder Used	Stroke	Cylinder Model	Order No.	Speed (in./min.)†† Advance	Pressing	Type Pump	Valve Type	Pump Model***	Prod. Wt. (lbs.)
150	Double-Acting	13⅞"	RD15013	SPE15013DS	24	3.9	Electric*	4-way**	PQ1204S	3,015
200	Double-Acting	13⅞"	RD20013	SPE20013DS	18	2.9	Electric*	4-way**	PQ1204S	3,276

† Frame is shipped assembled.

†† Typical performance based on 100 psi and 10,000 psi pump specifications. Actual speeds may vary under operating conditions.

* Pre-wired at factory for 460V.

** Solenoid valve with 24 volt remote control hand switch.

*** Pump standard with press. Other Power Team pumps can be substituted. dBA at idle and 10,000 psi: 73/78, measured at 3 foot distance, all sides.

ROLL-BED® PRESS

80-200 Ton

H Frame

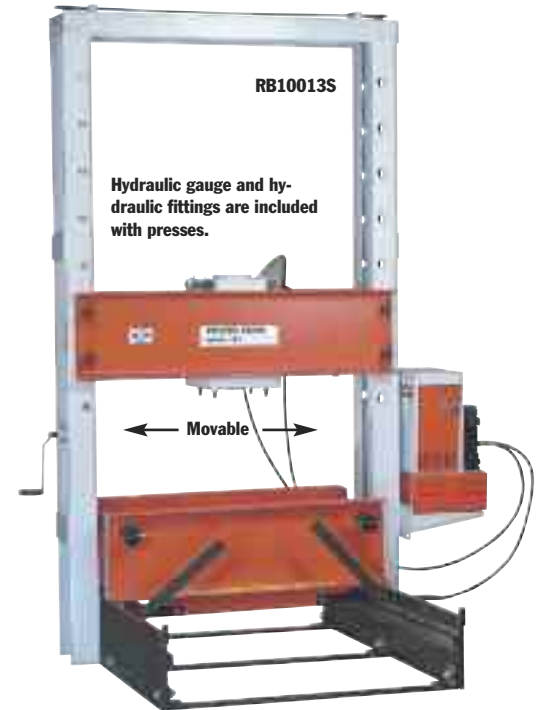

Heavy-Duty Straightening Fixtures



No. SF50 – Fixtures for use with 80-ton Roll-Bed® presses or 55-ton heavy-duty shop presses. (2 ea.). Wt. 104 lbs. **Not part of press, order separately.**



No. SF150 – Fixtures for use with 100-, 150- and 200-ton Roll-Bed® presses and 100-ton shop presses only (1 pr.). Wt. 196 lbs. **Not part of press, order separately.**



- The original, patented Roll-Bed® design. Bed rolls out for easy loading and unloading with a crane or other lifting device.
- Movable workhead glides easily side-to-side for full off-center load capacity across width of upper frame.
- “Daylight” is 50½" x 60" for 80- and 100-ton models; 51¼" x 64" on 150- and 200-ton presses.
- Fast approach of double-acting, 13⅜" stroke cylinder is provided by PQ1204S “Quiet” electric/hydraulic pump with remote control hand switch. Operator can view work from all sides with fingertip control of cylinder piston travel.

PRESS FEATURES:

- **Roll-Bed® design** – Bed glides in or out on bearings to make loading and unloading fast and easy.
- **Adjustable lower bed width** – For secure balancing and centering of heavy jobs. Loosen adjusting bolts to adjust bed from 4" to more than 27". See dimension “H.”
- **Movable workhead** – For off-center pressing jobs, workhead moves on bearings across upper bolster. Presses can be used at full capacity, regardless of where workhead is placed.
- **Lifting mechanism** – Simply turn crank handle to raise or lower upper bolster. Screw mechanism raises or lowers both sides evenly (a heavy-duty ½" drill motor can replace handle for automatic adjustment). Four locking pins hold bolster in place for pressing.

- **Optional heavy-duty straightening fixtures** – Make straightening jobs easy and accurate to within .004"! Rollers are ball bearing mounted and handle raises or lowers for easy turning of the work.

PUMP ELECTRICAL SPECIFICATIONS

PQ120 Series – 3 hp, 460 volt, 60 cycle, three phase. Available in 220/380 volt, 50 cycle, add suffix “-380” to order no.

NOTE: To order press with a 230 volt, 60 cycle, single phase pump, order press less PQ1204S. Order pump No. PQ604S separately.

NOTE: Different voltage and valve options can be obtained by substituting certain PA, PE or PQ series pumps. Consult the factory.



Lifting screw and locking pins make bolster raising a one-man job.



Bearings make bed positioning smooth and easy.



Lever lowers bed for pressing, raises it for rolling.



Cylinder is easily moved across width of upper bolster.



Width adjusts from 4" to over 27"; is secured with locking bolts.

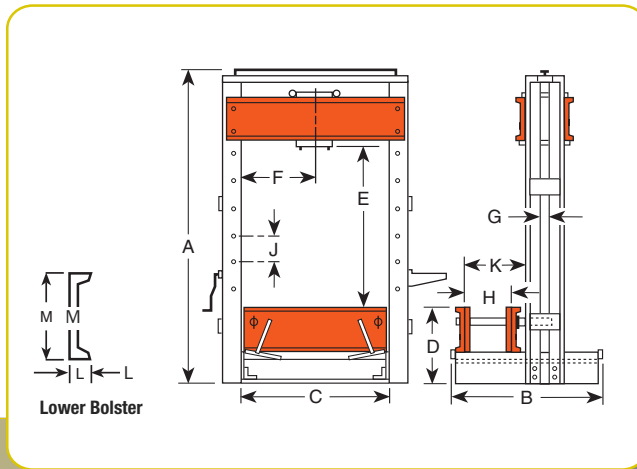

DIMENSIONS

Cap Tons	A (in.)	B (in.)	C (in.)	D (in.)	E (in.)	F (in.)	G (in.)	H (in.)	J (in.)	K (in.)	L (in.)	M (in.)	Floor Space
80	112 ⁵ / ₈	64 ¹ / ₄	50 ¹ / ₂	27	12 - 60	14 ¹ / ₂ - 36	3	4 - 27 ¹ / ₄	8	36 ¹ / ₂	3 ³ / ₈	15	64 ¹ / ₄ x 60 ¹ / ₂
100	112 ⁵ / ₈	64 ¹ / ₄	50 ¹ / ₂	27	12 - 60	14 ¹ / ₂ - 36	3	4 - 27 ¹ / ₄	8	36 ¹ / ₂	3 ³ / ₈	15	64 ¹ / ₄ x 60 ¹ / ₂
150	123 ³ / ₄	68 ³ / ₄	51 ¹ / ₄	30	9 - 64	13 ⁷ / ₈ - 37 ³ / ₈	3	4 - 27 ¹ / ₈	11	37 ¹ / ₄	4 ¹ / ₈	18	68 ³ / ₄ x 63 ¹ / ₄
200	123 ³ / ₄	68 ³ / ₄	51 ¹ / ₄	30	9 - 64	15 ¹ / ₈ - 36 ¹ / ₈	3	4 - 27 ¹ / ₈	11	37 ¹ / ₄	4 ¹ / ₈	18	68 ³ / ₄ x 63 ¹ / ₄



ORDERING INFORMATION

Capacity (tons)†	Type of Cylinder Used	Stroke	Cylinder Model	Order No.	Speed (in./min.)††	Type Pump	Valve Type	Pump‡ Model	Prod. Wt. (lbs.)
80	Double-Acting	13 ¹ / ₈ "	RD8013	RB8013S	46 7.5	Elec.	4-way*	PQ1204S	2,886
100	Double-Acting	13 ¹ / ₈ "	RD10013	RB10013S	35 5.8	Elec.	4-way*	PQ1204S	2,944
150	Double-Acting	13 ¹ / ₈ "	RD15013	RB15013S	24 3.9	Elec.	4-way*	PQ1204S	4,458
200	Double-Acting	13 ¹ / ₈ "	RD20013	RB20013S	18 2.9	Elec.	4-way*	PQ1204S	4,546

* Solenoid valve with 24 volt remote control hand switch.

† Frame is shipped assembled.

‡ Pump standard with press. Other Power Team pumps can be substituted. dBA at idle and 10,000 psi: PQ120-73/78; measured at 3 foot distance, all sides.

†† Typical performance based on 100 psi and 10,000 psi pump specifications. Actual speeds may vary with operating conditions.

3,000 lbs maximum load can be supported on bed when raised on the rollers.

SHOP PRESS

Accessories

Rubber Tire Removing/Installing set

Now an easy way to press solid rubber tires. The TPP200 uses plates instead of combination rings to press a rim from an old tire into a new one. Plates are stacked so none is more than 2 in. smaller than the one under it to keep the plates from bending. They can be used on any Power Team press with 55-ton capacity or more. NOTE: Many tires require 100 tons of force or more, depending on tire size and condition. These plates withstand max. force of 150 tons.

No. TPP200 – Tire press plate set. Includes 13 press plates, spacer pushing adapter and press bed plate. For use on solid rubber tires from 4" to 17³/₄" I.D.

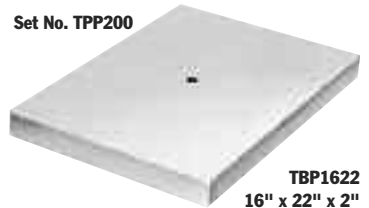

TBP1622
16" x 22" x 2"



TPP1 - TPP13
3⁷/₈" - 17⁵/₈" x 3³/₄"



TPS6
3³/₄" x 6"

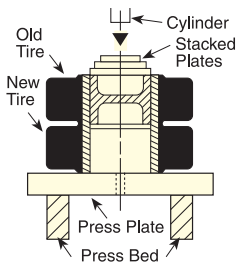

Pressing rim into new tire on Power Team Press.



Order No.	Set No. TPP200 Tire Size I.D.	Plate O.D.
TPP1	4"	3 ⁷ / ₈ "
TPP2	5"	4 ⁷ / ₈ "
TPP3	6", 6 ¹ / ₄ "	5 ⁷ / ₈ "
TPP4	6 ¹ / ₂ "	6 ³ / ₈ "
TPP5	8"	7 ⁷ / ₈ "
TPP6	10"	9 ⁷ / ₈ "
TPP7	10 ¹ / ₂ "	10 ³ / ₈ "
TPP8	11 ¹ / ₄ "	11 ¹ / ₈ "
TPP9	12", 12 ¹ / ₈ "	11 ⁷ / ₈ "
TPP10	14"	13 ⁷ / ₈ "
TPP11	15"	14 ⁷ / ₈ "
TPP12	16"	15 ⁷ / ₈ "
TPP13	17 ³ / ₄ "	17 ⁵ / ₈ "
TPS6	Spacer/Pushing Adapter	3 ³ / ₄ " x 6"
TBP1622	Bed Plate	16" x 22" x 2"

PRESS ACCESSORIES, "V" BLOCKS & THREADED ADAPTERS

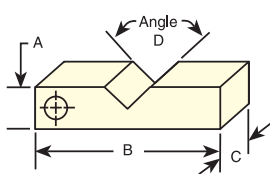

V-BLOCKS (in.)

Order No.	Width A	Length B	Thick C	Angle D
1890	2	9	1 ¹ / ₄	120°
1891	2 ¹ / ₂	11 ¹ / ₂	1 ³ / ₄	
1892	3 ¹ / ₂	14	2	
1893	5	14	1 ¹ / ₂	
207395	5 ³ / ₄	23	2 ¹ / ₂	

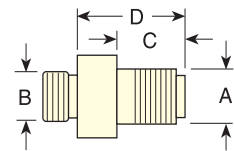

THREADED ADAPTER DIMENSIONS (in.)

Adapter No.	A	B	C	D
38597	1- 8	1- 8	3/4	1 ⁵ / ₁₆
38953	1 ¹ / ₄ - 7	1 ¹ / ₂ - 16	2 ³ / ₄	4 ³ / ₈
37368	1 ⁵ / ₈ - 5 ¹ / ₂	—	1 ¹¹ / ₁₆	2 ¹ / ₂
43562	2 ¹ / ₄ - 12	—	2 ¹ / ₄	3
38954	1 ⁵ / ₈ - 5 ¹ / ₂	1 ¹¹ / ₁₆ - 8	3 ¹ / ₄	4 ³ / ₁₆
43563	2 ¹ / ₄ - 12	2 ³ / ₄ - 12	2 ¹ / ₄	3 ³ / ₁₆
46070	2 ¹ / ₄ - 12	2 - 4 ¹ / ₂	2 ¹ / ₄	3 ³ / ₁₆

Press Accessory Kit

Make your Power Team press even more versatile with one of these accessory sets. These sets will eliminate makeshift set-ups. Many of these items can be used with pullers you already have.

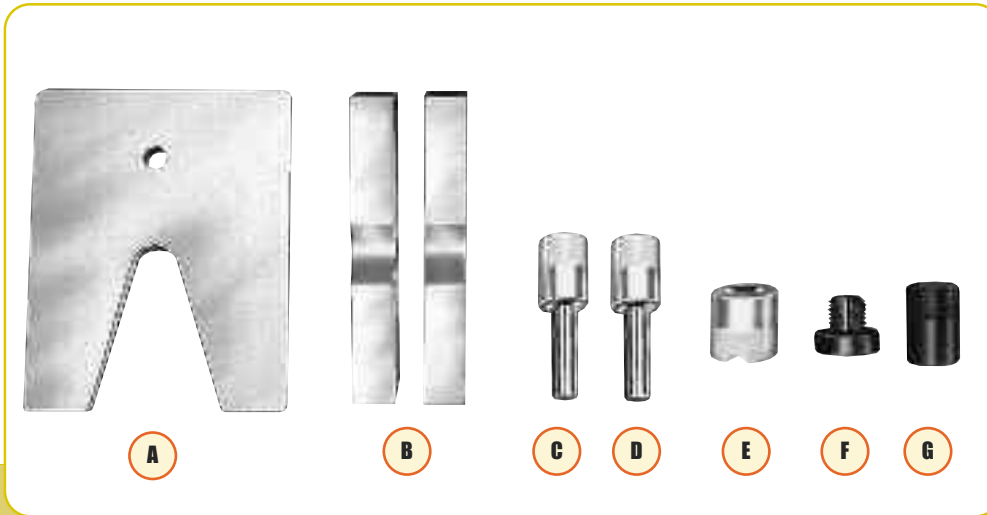

ORDERING INFORMATION

Use With Press:	Order No.	A		C	D	E	F		G
		Press Plate	V-Blocks				Pushing Adapter	Pushing Adapter	
10 Ton	SPA10	1888	1890 (Pr.)	201923 1/2" dia. shank	201454 3/4" dia. shank	34806	Included in Set 38597		
25 Ton	SPA25	1889	1891 (Pr.)	34510 3/4" dia. shank	34511 1" dia. shank	34807	Included in Set 38953		
55 Ton	SPA55	—	1892 (Pr.)	34755 1" dia. shank	34756 1 1/2" dia. shank	34808	Not Included Order Separately — 37368		38954
80/100 Ton	SPA100	—	1893 ** (Pr.)	—	—	36469	Not Included Order Separately 43562		21332
150/200 Ton	SPA200	—	207395 (Pr.)	—	44458 2 1/4" dia. shank	44457	None* 46070 ***		46070

* Pushing adapters thread directly into RD15013 and RD20013 cylinders.

** V-blocks, No. 1893, are recommended for use with 80-ton Roll-Bed® press. Not recommended for use with 100-ton Roll-Bed®.

*** For 80-ton Roll-Bed® press.

NOTE: Individual press accessories may be ordered separately.



CAUTION: Pushing adapters are designed for use with specific shaft sizes, and depending on the condition of the shaft ends, the adapter may not withstand the full press tonnage. Always use a protective blanket or other suitable guard when pressing.

SHOP EQUIPMENT



MOBILE FLOOR CRANES

2200-4400 lbs.

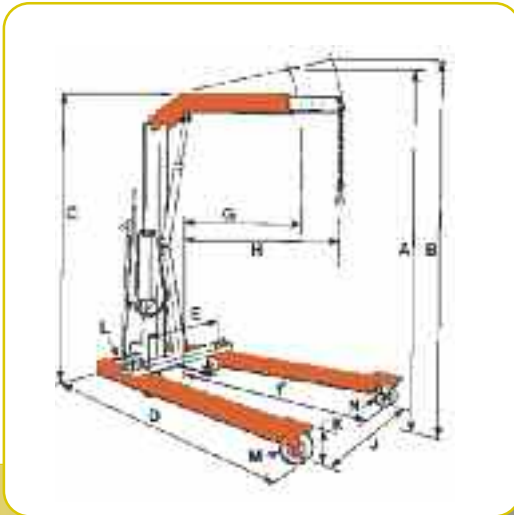

DIMENSIONS

	FC2200*	FC4400*
Cap., boom ret. (lbs.)	2,200	4,400
Cap., boom ext. (lbs.)	1,650	3,300
A Max. boom hgt., (ret.)	107"	111"
B Max. boom hgt., (ext.)	117"	122"
C Overall hgt., boom horiz.	80"	82"
D Overall length	83"	89"
E Min. throat width	24"	25"
F Inside leg length	54"	57½"
G Eff. boom reach (ret.)	33"	35½"
H Eff. boom reach (ext.)	48"	50½"
J Inside leg width	24" - 36" - 48"	26" - 40" - 52½"
	(3-position)	(3-position)
K Leg height	8"	9½"
L Dolly wheel diameter	5"	5"
M Wheel diameter	6"	8"
N Caster diameter	6"	6"
Floor space, folded	27" x 38"	31" x 42"
Height, folded	79"	86"

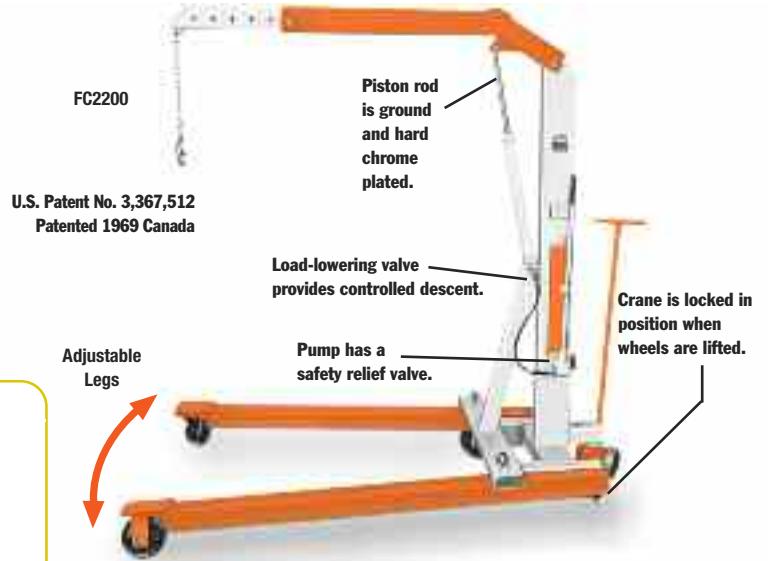

2,200 lbs. and 4,400 lbs. capacity with space-saving fold-away feature

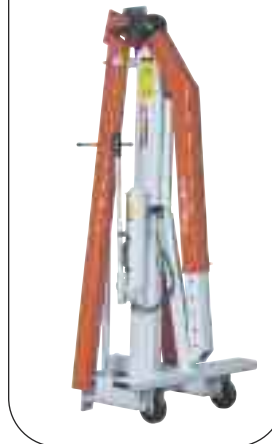

- Adjustable legs spread to clear obstacles, telescoping boom for extra reach. Rugged construction, reliable hydraulics.
 - Boom collapses completely and legs fold for compact storage.
 - 2-speed hydraulic hand pump provides fast boom travel and precise operator controlled descent.
 - Roller bearing wheels and a steering dolly provide ease of mobility. Lifting chain is included.
- No. FC4400** – 4,400 lbs. cap. crane with fold-away feature, adj. leg spread, lifting chain and 2-speed hand pump. Wt., 646 lbs.

LOAD-ROTORS®

TILTERS

2000-6000 lbs.

Load-Rotors®



"Tilter" LR6000
6,000 Lbs. Capacity



LR2000
2,000 Lbs.
Cap.

LR4000
4,000 Lbs.
Cap.



- For lifting or positioning components, Power Team's heavy duty lifting slings are just right.
- The heavy-duty Load-Rotors®, when used with a crane or hoist, greatly reduce time and effort.
- A self-locking worm and gear set in the Load-Rotor® head permits rapid angle adjustment of the component being handled.
- Whenever you have big, heavy components to move or position, nothing helps you get the job done easier and faster than the 6,000 lb. "Tilter."

* Note: not to be used for overhead lifting.

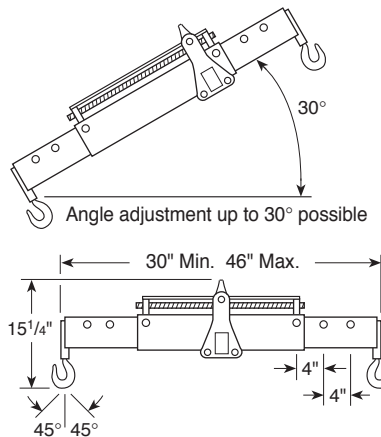

The working length is adjustable in three positions from 30" to 46". Maximum chain angle is 45°.



ORDERING INFORMATION

Capacity (lbs.)	Order No.	Chain Size (in.)	Chain Lg. W/ Swivel Hooks (in.)	Lifting Eye Opening (in.)	Hex Drive End (in.)	Gear Ratio	Product Wt. (lbs.)
2000	LR2000	1/4	56	1 1/4	5/8	34:1	9
4000	LR4000	5/16	65	1 3/4	5/8	82:1	23
6000	LR6000	5/16	65	1 5/8	5/8	82:1	73