

Electric Pump HYDRAULIC PE17 SERIES

Up to 55 Ton
279 cm³/min.
2 Speed

For maintenance and construction applications.

- For use with single-acting or double-acting cylinders at operating pressures to 700 bar.
- For intermittent duty; starts under full load.
- Equipped with 0,37Kw (½ hp), 3,450 rpm, single-phase, thermal protected induction motor; 3 m remote control cord (PE172S has 7,6 m cord)
- Low amperage draw; small generators and low amperage circuits can be used as power source.
- Extremely quiet noise level (67-81 dBA).



PE172

700 bar



PUMPS

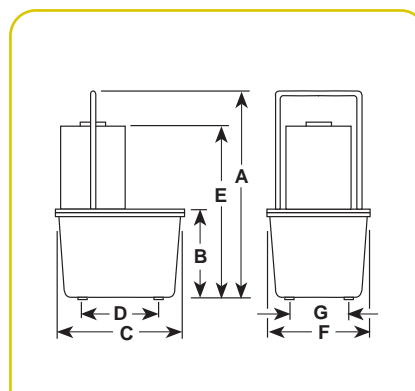
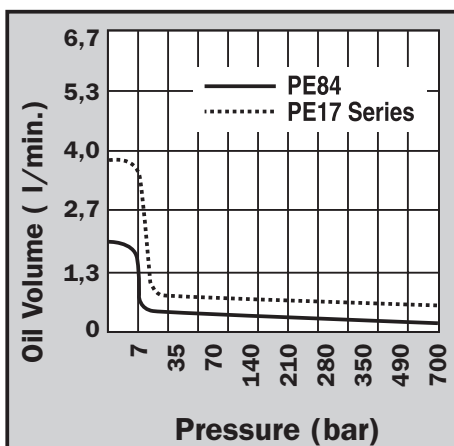

Pump No.	Max. Pressure Output bar	rpm	dBA at Idle and 700 bar	Amp Draw 220 V - at 700 bar	Oil Del. (liters/min. @) †				A (mm)	B (mm)	C (mm)	D (mm)	E (mm)	F (mm)	G (mm)	Prod. Wt. with Oil (kg)
					0 bar	7 bar	350 bar	700 bar								
PE17 Series	700	2850	67/81*	5	3,9	2,5	0,3	0,2	470	178	289	181	378	235	130	20,4
PE17M Series	700	2850	67/81*	5	3,9	2,5	0,3	0,2	460	168	292	—	368	241	—	24,0

* Measured at 0,9 m distance, all sides.

† Typical delivery. Actual flow will vary with field conditions.



PE172SM



PE174



Description	Order No.	Valve Type	Valve No.	Valve Function	Control Switch ††	Motor	Reservoir Usable (l)
Base model pump with 0,37 KW pump with 7,6 l thermoplastic reservoir.	PE172-50-220	2-Way	9517	Advance Return (Auto†)	Remote Motor Control (3,1m) on/off	0,37 kW, 220 V* 50/60 Hz, Single Phase	4,72
PE172-50-220, except has 9,5 l aluminum reservoir.	PE172M-50-220	2-Way	9517	Advance Return (Auto†)	Remote Motor Control (3,1m) on/off	0,37 kW, 220 V* 50/60 Hz, Single Phase	6
PE172-50-220, except has solenoid operated valve.	PE172S-50-220	3-Way	9570	Advance Hold Return	Remote Motor & Valve (7,6 m)	0,37 kW, 220 V* 50/60 Hz, Single Phase	4,72
PE172S-50-220, except has aluminum reservoir.	PE172SM-50-220	3-Way	9570	Advance Hold Return	Remote Motor & Valve (7,6 m)	0,37 kW, 220 V* 50/60 Hz, Single Phase	6
Best suited for crimping, punching, pressing. Thermoplastic reservoir.	PE172A-50-2208	Auto./Dump Manifold	45554	Advance Return	Remote Motor Control (3,1 m) on/off	0,37 kW, 220 V* 50/60 Hz, Single Phase	4,72
PE172A, except has aluminum reservoir.	PE172AM-50-2208	Auto./Dump Manifold	45554	Advance Return	Remote Motor Control (3,1 m) on/off	0,37 kW, 220 V* 50/60 Hz, Single Phase	6
0,37 KW pump with 7,6 l thermoplastic reservoir. Meets CE requirements.	PE172-E220	2-Way	9517	Advance Return (Auto+)	Remote Motor Control (3,1 m) on/off	CE	4,72
PE172-50-220, except has 9,5l aluminium reservoir. Meets CE requirements	PE172M-E220	2-Way	9517	Advance Return (Auto+)	Remote Motor Control (3,1 m) on/off	CE	6
PE172-50-220, except has solenoid operated valve. Meets CE requirements	PE172S-E220	3-Way	9570	Advance Hold Return	Remote Motor & Valve (3,1m)	CE	4,72
PE172S-50-220 except has aluminium reservoir. Meets CE requirement	PE172SM-E220	3-Way	9570	Advance Hold Return	Remote Motor & Valve (3,1m)	CE	6
Best suited for crimping, punching, pressing. Thermoplastic res. Meets CE requirement	PE172A-E220∞	Auto./Dump Manifold	45554	Advance/Return	Remote Motor Control (3,1 m) on/off	CE	4,72
PE172A, except has aluminium reservoir. Meets CE requirements	PE172AM-E220∞	Auto./Dump Manifold	45554	Advance/Return	Remote Motor Control (3,1 m) on/off	CE	6
PE172-50-220, except has 9500 double-acting valve.	PE174-50-220	4-Way	9500	Advance Hold Return**	Remote Motor Control (3,1 m) on/off	0,37 kW, 220 V* 50/60 Hz, Single Phase	4,72
Same as PE174-50-220, except has aluminum reservoir.	PE174M-50-220	4-Way	9500	Advance Hold Return**	Remote Motor Control (3,1 m) on/off	0,37 kW, 220 V* 50/60 Hz, Single Phase	6
PE172-50-220, except has 9500 double-acting Valve. Meets CE requirements	PE174-E220	4-Way	9500	Advance Hold Return**	Remote Motor Control (3,1 m) on/off	CE	4,72
Same as PE174-50-220, except has aluminium Reservoir. Meets CE requirements	PE174M-E220	4-Way	9500	Advance Hold Return	Remote Motor Control (3,1 m) on/off	CE	6

- * Available with 115V, 60 Hz motor (to order , remove suffix "50-220" behind pump order number).
- ** "Advance" position holds pressure with motor shut off.
- † "Advance" position holds pressure with motor shut off. "Return" position advances cylinder with motor running and returns cylinder with motor shut off.
- †† Control switch on PE17 series wired with line voltage.
- ∞ Not to be used for lifting.

NOTE: The remote motor control switch on 220V, 50 cycle PE17 series pumps is 24 volt (non CE).

NOTE: Usable oil is calculated with the oil fill at the recommended maximum level of 38 mm below reservoir cover plate.
 ‡ **Some Power Team pumps are available in special configurations not listed in this catalog. Power Team can "Assemble to Order" pumps with special seals, voltages, valves, relief valve settings, etc. For your special requirements please consult your local distributor or the Power Team factory.**

Also available in CE | E 110



Electric Pump

HYDRAULIC PE18 SERIES

Up to 55 Ton

295 cm³/min.

Vanguard Jr. Series[®]

Ideal for use with small hydraulically powered tools.

PUMPS

- Vanguard Jr.[®] pumps provide two-speed high performance in a light-weight, compact package.
- Gauge port provided on pump. Metal reservoir on all models.
- Equipped with a 0,37Kw (½ hp), 220 volt, 50 Hz single phase motor that starts under load, even at reduced voltage.
- Low amperage draw permits use with smaller generators and low amperage circuits.
- All pumps have a 3 m remote control (PE183C has 7,6 m remote control).
- CSA rated for intermittent duty. Noise level of 85-90 dBA.



PE182

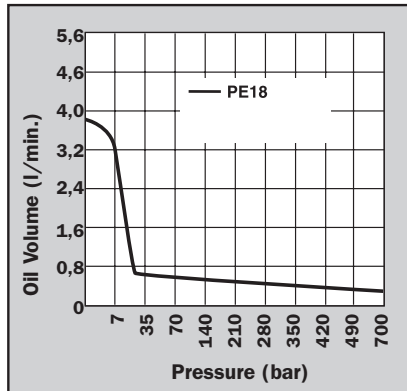

For operating hydraulic crimping, cutting or other tools:

- **No. PE183C** - For crimping or pressing applications. Has special electrical circuitry to pulse/advance, hold at full pressure, build to a predetermined pressure, release and reset circuit. Features separate emergency return switch.
- **No. PE184C** - Allows you to alternately operate a spring-return cutting and/or crimping tool without disconnecting either tool. Select port connection with manual 4-way valve, start pump with remote control hand switch and extend connected tool. When hand switch is switched to off, pump stops and automatic valve opens, allowing tool to return. In center (neutral) position, manual control valve holds tool in position at time valve is shifted.

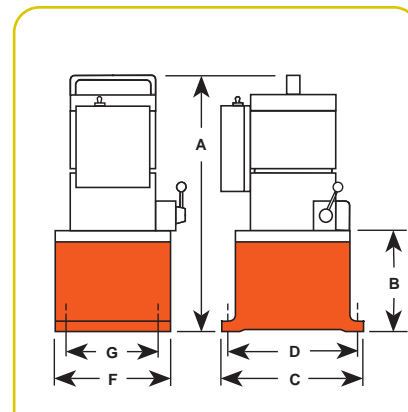

700 bar



Pump No.	Max. Pressure Output		dBA at Idle and 700 bar	Amp Draw 220 V at 700 bar				Oil Del. (liters./min. @) †				Prod. Wt. with Oil (kg)			
	bar	rpm		bar	bar	bar	bar	bar	bar	A (mm)	B (mm)		C (mm)	D (mm)	F (mm)
PE182	700	12.000	85/90**	4,5 Amp.	3,7	3,0	0,4	0,3	406	121	203	181	152	130	13,6
PE183	700	12.000	85/90**	4,5 Amp.	3,7	3,0	0,4	0,3	406	121	203	181	152	130	13,6
PE183A	700	12.000	85/90**	4,5 Amp.	3,7	3,0	0,4	0,3	406	121	203	181	152	130	13,6
PE184	700	12.000	85/90**	4,5 Amp.	3,7	3,0	0,4	0,3	406	121	203	181	152	130	13,6
PE183-2*	700	12.000	85/90**	4,5 Amp.	3,7	3,0	0,4	0,3	470	184	292	254	241	203	19,0
PE184-2*	700	12.000	85/90**	4,5 Amp.	3,7	3,0	0,4	0,3	470	184	292	254	241	203	19,0
PE183C ††	700	12.000	85/90**	4,5 Amp.	3,7	3,0	0,4	0,3	406	121	203	181	152	130	13,6
PE184C ††	700	12.000	85/90**	4,5 Amp.	3,7	3,0	0,4	0,3	406	121	203	181	152	130	13,6

* 9,5 l reservoir.

** Measured at 0,9 m distance, all sides.

† Typical delivery. Actual flow will vary with field conditions.

†† Special application pumps for cutting, crimping or pressing.



PE183-2



PE183C

For use with cyl. type	Description	Order No.	Valve Type	Valve Function	Control Switch	Motor	Reservoir Usable (l)
Single-acting	Base model pump has 0,37 KW pump with 2-Way valve and 1,9 l reservoir.	PE182-50-220	2-Way	Advance Return†	Remote Motor Control (3,1 m) on/off	0,37 kW, 220 V** 50 Hz, A.C., Single Phase	1,7
Single-acting	PE182-50-220, except has 3-way valve.	PE183-50-220	3-Way	Advance Hold Return	Remote Motor Control (3,1 m) on/off	0,37 kW, 220 V** 50 Hz, A.C., Single Phase	1,7
Single-acting	PE183-50-220, except has 9,5 l reservoir.	PE183-2-50-220	3-Way	Advance Hold Return	Remote Control (3,1 m)	0,37 kW, 220 V** 50 Hz, A.C., Single Phase	8,4††
Single-acting	PE183-50-220, except has "dump valve".	PE183A-50-220∞	Auto./Dump Pump	Advance Return	Remote (3,1 m)	0,37 kW, 220 V** 50 Hz, A.C., Single Phase	1,7
Single-acting	Special crimping pump. See details on page 74.	PE183C-50-220∞	Special, for crimping only	Advance Hold Return	Remote Motor Control (7,6 m) on/off	0,37 kW, 220 V** 50 Hz, A.C., Single Phase	1,7
Single-acting/ double-acting	Base model pump has 0,37 KW pump for double-acting systems with 1,9 l reservoir.	PE184-50-220	4-Way	Advance Hold Return†	Remote Motor Control (3,1 m) on/off	0,37 kW, 220 V** 50 Hz, A.C., Single Phase	1,7
Single-acting/ double-acting	PE184, except with 9,5 l reservoir.	PE184-2-50-220	4-Way	Advance Hold Return†	Remote Motor Control (3,1 m) on/off	0,37 kW, 220 V** 50 Hz, A.C., Single Phase	8,4††
Single-acting/ double-acting	Special crimping pump. See details on page 74.	PE184C-50-220*	4-Way	Advance Return	Remote Control (3,1 m) on/off	0,37 kW, 220 V** 50 Hz, A.C., Single Phase	1,7

* Also for use with special single-acting cylinder applications.
 ** Available with 115 Volt, 50 Hz motor (to order, remove suffix "50-220" behind pump order number). Specify voltage when ordering.

† Holds when motor is shut off and valve is in "advance" position.
 †† Pumps supplied with 7,6 l oil (usable oil is 5,7 l), will hold 9,5 l when filled to within 13 mm below reservoir cover plate.
 ∞ Not to be used for lifting.



Electric Pump

PE21 SERIES

Up to 75 Ton
361 cm³/min.
Two-Speed

Low-speed, high-torque for heavy-duty, extended-cycle operations.

PUMPS

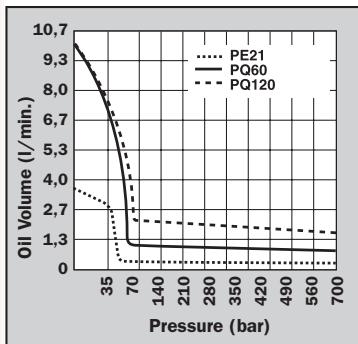

- Totally enclosed, fan cooled induction motor: 0,75Kw (1 hp), 1,725 rpm, 60 Hz, single phase. Thermal overload protection.
- Remote control, with 3,1 m cord is standard on pumps with solenoid valves. Manual valve pumps have “Stop”, “Start” and “Run/Off/Pulse” switches. Pump controls are moisture and dust resistant.
- Motor drip cover with carrying handles and lifting lug.
- Low noise level of 70 dBA[®] 700 bar.
- In the event of electrical interruption, pump shuts off and will not start up until operator presses the pump start button.
- 24 volt control circuits on units with remote controls provide additional user/operator safety.



PE213



PE21 series pump and RD5513 cylinder used in a special press that produces pharmaceutical-grade extracts for herbal medicines.

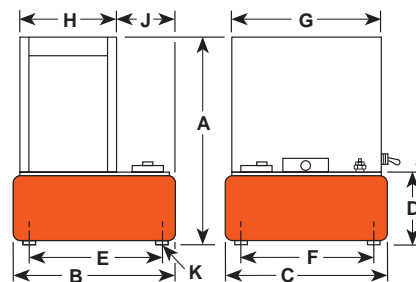

Pump No.	Max. Pressure Output		dBA at Idle and 700 bar	Oil Del. (l/min. at.)	700 bar			A (mm)	B (mm)	C (mm)	D (mm)	E (mm)	F (mm)	G (mm)	H (mm)	J (mm)	K ^{***} (in)	Prod. Wt. w/Oil (kg)
	bar	rpm			70 bar	350 bar	700 bar											
PE21 Series	700	1.437	70*	3,6	0,4	0,4	0,3	543	292	241	165	254	203	359	241	82,6	1/2-20 UNF	44,4†

* Measured at a 0,9 m distance, all sides.

*** For 50,8 mm dia. swivel casters, order (4) No. 10494.

† Shipping weight with manual valve; add 6,4 kg for pump with solenoid valve.



PE214

700 bar



PE214S

For use with cyl.-type	Description	Order No.	Valve Type	Valve No.	Valve Function	Max. Amp Draw at 700 bar	Motor	Reservoir Usable (l)
Single-acting	0,75 KW pump with 9,5 l Reservoir and manual valve.	PE213-50-220	3-Way	9520*	Advance Hold Return	230 V - 7,5 amps	0,75 KW, 220 Volt 50 Hz, Single Phase	590
Single-acting	PE213, except has solenoid operated remote valve.	PE213S-50-220	3-Way	9599†	Advance Hold Return	230 V - 7,5 amps	0,75 KW, 220 Volt 50 Hz, Single Phase	590
Double-acting	0,75 KW pump with 9,5 l Reservoir and manual valve.	PE214-50-220	4-Way	9506*	Advance Hold Return	230 V - 7,5 amps	0,75 KW, 220 Volt 50 Hz, Single Phase	590
Double-acting	PE214, except has solenoid operated remote valve.	PE214S-50-220	4-Way	9512†	Advance Hold Return	230 V - 7,5 amps	0,75 KW, 220 Volt 50 Hz, Single Phase	590

* Manual valve. Pump is equipped with RUN/OFF/PULSE switch for control of motor.

† Solenoid valve. Pump is equipped with a remote control switch with 3,1 m cord.

Some Power Team pumps are available in special configurations not listed in this catalog. Power Team can "Assemble to Order" pumps with special seals, voltages, valves, relief valve settings, etc. For your special requirements please consult your local distributor or the Power Team factory.



Electric Pump HYDRAULIC PE46 SERIES

0,6 l/min
Two-speed

Best suited for under the roof maintenance and production applications.

PUMPS

- Two-speed high performance pump.
- For use with single- or double-acting cylinders at operating pressures to 700 bar.
- Equipped with a 1.12 KW, 2.875 rpm single-phase, 50 Hz thermal protected induction motor that starts under full load. Noise level of 77-81 dBA.
- All equipped with a 3,1 m remote control except PE462S which has a 7,6 m remote control.
- 24 volt control circuit on all units with remote control.
- CSA rated for intermittent duty.



700 bar

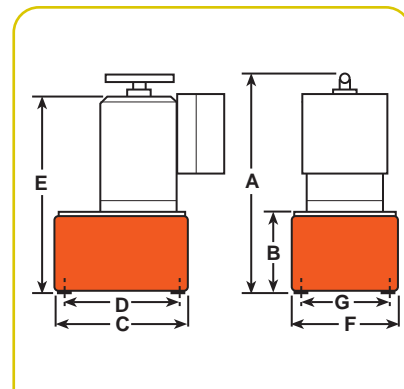
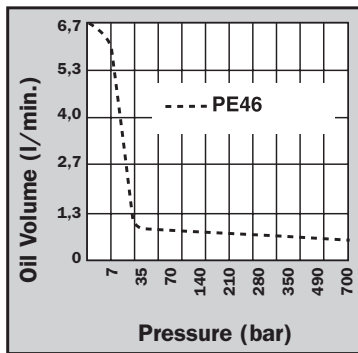

Pump No.	Max. Pressure Output bar	rpm	Noise level at Idle and 700 bar (dBA)	Amp Draw 220 V - at 700 bar (A)	Oil Del. (l/min. at.)†				A (mm)	B (mm)	C (mm)	D (mm)	E (mm)	F (mm)	G (mm)	Prod. Wt. w/Oil (kg)
					0 bar	7 bar	350 bar	700 bar								
PE46-Series	700	2.875	77/81	13	6,7	6,0	0,7	0,6	499	173	292	254	378	241	203	35,8
PE46-E220	700	2.875	77/81*	13	6,7	6,0	0,7	0,6	499	173	292	254	378	241	203	41,3

* Measured at 0,9 m distance, all sides.

† Typical delivery. Actual flow will vary with field conditions.



PE462S



PE464

For use with cyl.-type	Description	Order No.	Valve Type	Valve No.	Valve Function	Control Switch†††	Motor	Reservoir Usable*** (l)
Single-acting	Base model 1,12 KW pump with 9,5 l metal reservoir.	PE462-50-220	3-Way	9584	Advance Return†	Remote Motor Control (3,1 m) on/off	1,12 KW, 220 VAC* 50 Hz, Single Phase	9,4
Single-acting	PE462-50-220, except has solenoid valve.	PE462S-50-220	3-Way	9570	Advance Return**	Remote Motor valve (7,6 m)	1,12 KW, 220 VAC* 50 Hz, Single Phase	9,4
Single-acting	PE462-50-220, except has "dump valve"	PE462A-50-220∞	Auto/Dump 3-Way	9610	Advance Return	Remote Motor Control (3,1 m) on/off	1,12 KW, 220 VAC* 50 Hz, Single Phase	9,4
Single-acting	1,12 KW pump with 9,5l metal reservoir. Meets CE requirement	PE462-E220	3-Way	9584	Advance Return +	Remote Motor Control (3,1 m) on/off	1,12 KW, 220 VAC* 50 Hz, Single Phase	9,4
Single-acting	PE462-50-220, except has solenoid valve. Meets CE requirement	PE462S-E220	3-Way	9570	Advance Return**	Remote Motor/Valve (7,6 m)	1,12 KW, 220 VAC* 50 Hz, Single Phase	9,4
Single-acting	PE462-50-220, Except has "dump valve". Meets CE requirement	PE462A-E220∞	Auto/Dump 3-Way	9610	Advance Return	Remote Motor Control (3,1 m) on/off	1,12 KW, 220 VAC* 50 Hz, Single Phase	9,4
Double-acting/ multi-single-act.	PE462-50-220, except has 9500 double-acting valve.	PE464-50-220	4-Way	9500	Advance Hold Return†	Remote Motor Control (3,1 m) on/off	1,12 KW, 220 VAC* 50 Hz, Single Phase	9,4
Double-acting/ multi-single-act.	Same as PE464-50-220 Meets CE requirement	PE464-E220	4-Way	9500	Advance Hold Return +	Remote Motor Control (3,1 m) on/off	1,12 KW, 220 VAC* 50 Hz, Single Phase	9,4
Double-acting/ multi-single-act.	Same as PE464S-50-220 Meets CE requirement	PE464S-E220	3/4-Way	9552	Advance Return**	Remote Motor/Valve (3,1m)	1,12 KW, 220 VAC* 50 Hz, Single Phase	9,4
Double-acting/ multi-single-act.	PE462S-50-220, except has 9592 double-acting valve.	PE464S-50-220	3/4-Way	9552	Advance Return**	Remote Motor/Valve (3,1m)	1,12 KW, 220 VAC* 50 Hz, Single Phase	9,4

* Available with 115 V, 60 Hz motor (to order, remove suffix "50-220" behind pump order number). Specify voltage when ordering.

** "Advance" position holds pressure with motor shut off.

*** Usable oil is calculated with the oil fill at the recommended level of 13 mm below reservoir cover plate.

† "Advance" position holds pressure with motor shut off.
"Return" position returns cylinder.

††† The remote motor control switch on PE46 series pumps is 24 volt.

∞ Not to be used for lifting. When pump is shut off, oil returns to reservoir.



Electric Pump HYDRAULIC PE55 VANGUARD®

0,9 l/min
For cylinders up to
200 tons.

Heavy duty multiple-applications pump. Heavy construction and concrete stressing. Low voltage starting possible.

PUMPS

- 0,48Kw, 12,000 rpm, 220 volt, 50 Hz universal motor; draws 25 amps at full load, starts at reduced voltage. CSA rated for intermittent duty.
- 3,1 m remote motor control (except PE552S which has a 7,6 m remote motor and valve control).
- True unloading valve achieves greater pump efficiency, allowing higher flows at maximum pressure.
- Reservoirs available in sizes up to 38 l. See accessories page 119.
- Light weight and portable. Best weight to performance ratio of all Power Team pumps.

- “Assemble to Order” System: There are times when a custom pump is required. Power Team’s “Assemble to Order” system allows you to choose from a wide range of pre-engineered, off-the-shelf components to build a customized pump to fit specific requirements. By selecting standard components you get a “customized” pump without “customized” prices. All pumps come fully assembled, less oil and ready for work. See pages 112-115.

PE55TWP
Torque Wrench
Applications
See page 172

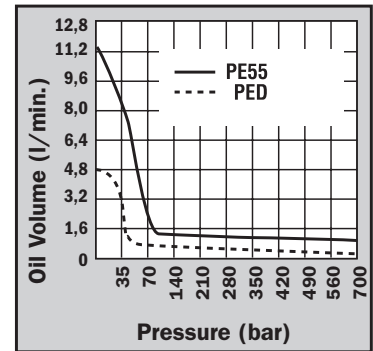

PE554W
The new pump;
weather-resistant.

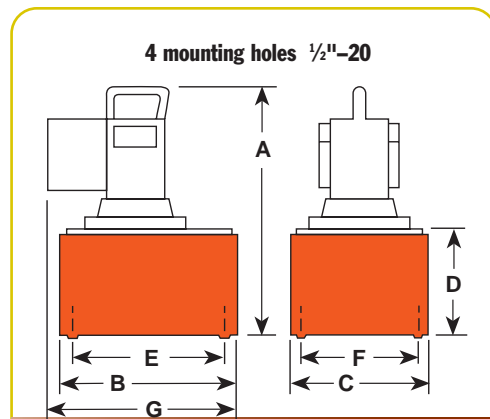

Pump No.	Max. Pressure Output		Noise level Idle and at 700 bar (dBA)	Amp Draw at 700 bar (220 V.)** (A)		Oil Del. (l/min at..)				Prod. Wt. w/Oil (kg)						
	bar	rpm		0 bar	50 bar	350 bar	700 bar	A (mm)	B (mm)		C (mm)	D (mm)	E (mm)	F (mm)	G (mm)	
PE55-Series	700	12,000	90/89*	13	11,3	7,1	1,2	0,9	464	292	241	178	254	203	356	29,4
PE55-E220									520						391	

*Noise level reading (dBA) measured at a 0,9 m distance, all sides.

** Amp draw at 700 bar, 230 Volts 60 Hz is 15 Amps.



PE554S



LR19814

700 bar



PE554PT



PE552

PUMPS

For use with cyl.-type	Description	Order No.***	Reservoir Valve Type	Valve No.	Valve Function	Control Switch ††	Motor	Usable (l)
Single-acting	Base model 0,84 KW pump with 9,5 l reservoir, remote motor control & 3-way valve.	PE552-50-220	3-Way	9582	Advance Return**	Remote Motor	0,84 KW*, 220 VAC 50Hz, Single Phase	8,4
Single-acting	PE552-50-220, except also has solenoid operated remote valve.	PE552S-50-220	3-Way	9570	Advance Hold Return	Remote Motor & Valve	0,84 KW*, 220 VAC 50Hz, Single Phase	8,4
Single-acting	PE552-50-220, except has "Auto Dump" valve.	PE552A-50-220	Auto/Dump	9610	Advance Return	Remote Motor	0,84 KW*, 220 VAC 50Hz, Single Phase	8,4
Single-acting	0,84 KW pump with 9,5 l reservoir. Valve has "Posi-check" feature.	PE553-50-220	3-Way†	9520	Advance Hold Return	Remote Motor	0,84 KW*, 220 VAC 50Hz, Single Phase	8,4
Single-acting	Same as PE552-50-220, but meets also CE requirement	PE552-E220	3-Way	9582	Advance Return**	Remote Motor	CE	8,4
Single-acting	Same as PE552S-50-220, but meets also CE requirement	PE552S-E220	3-Way	9570	Advance Return	Remote Motor & Valve	CE	8,4
Single-acting	Same as PE552A-50-220, but meets also CE requirements	PE552A-E220∞	Auto/Dump	9610	Advance Hold Return	Remote Motor	CE	8,4
Single-acting	Same as PE553-50-220 but needs also CE Requirement	PE553-E220	3-Way	9520	Advance Hold Return	Remote Motor	0,84 KW*, 220 VAC 50Hz, Single Phase	8,4
Double-acting	Base model 0,84 KW pump with 9,5 l res. and 4-way valve for double-acting systems.	PE554-50-220	4-Way†	9506	Advance Hold Return	Remote Motor	0,84 KW*, 220 VAC 50Hz, Single Phase	8,4
Double-acting	Same as PE554-50-220 but needs also CE Requirement	PE554-E220	4-Way†	9506	Advance Hold Return	Remote Motor	0,84 KW*, 220 VAC 50Hz, Single Phase	8,4
Double-acting	PE554-50-220, except has 9500 tandem center valve.	PE554T-50-220	4-Way	9500	Advance Hold Return	Remote Motor	0,84 KW*, 220 VAC 50Hz, Single Phase	8,4
Double-acting	For use with single-acting Spring Seat, Stressing Jack or double-acting cylinder.	PE554P-50-220	4-Way	9500	Advance Hold Return	Remote Motor	0,84 KW*, 220 VAC 50Hz, Single Phase	8,4
Double-acting	For use with single- or double-acting Power Seat, Stressing Jacks ONLY.	PE554PT-50-220	4-Way	9628	Advance Hold Sequenced Return	Remote Motor	0,84 KW*, 220 VAC 50Hz, Single Phase	8,4
Double-acting	Pump suitable to run multiple spring return tools	PE554C-50-220	4-Way	9511†††	Advance Hold Return	Remote Motor	0,84 KW*, 220 VAC 50Hz, Single Phase	8,4
Double-acting	Pump equipped with 3/4-way solenoid valve.	PE554S-50-220	3/4-Way	9552	Advance Hold Return	Remote Motor & Valve	0,84 KW*, 220 VAC 50Hz, Single Phase	8,4
Double-acting	Pump suitable to run multiple Spring return cylinder	PE554C-E220	4-Way	9511+++	Advance Hold Return	Remote Motor	CE	8,4
Double-acting	Pump equipped with 3/4-way solenoid valve	PE554S-E220	3/4-Way	9552	Advance Hold Return	Remote Motor & Valve	CE	8,4

* Pumps available with 115 volt, 50 Hz motors. (to order remove the -50-220 suffix from the order code). See "Assemble to Order" pump options on pages 102-105.

** Holds with motor shut off.

*** To order PE55 series pumps with CSA approval, add "-C" to the Order No.

† Valves have "Posi-Check" feature.

†† Control switch wired with line voltage. All remotes are 3,1m long except for PE552S which is 7,6m long.

††† Valving allows alternate and independent operation of two different spring return tools. Valve holds pressure only while valve is in "A" or "B" port position with pump motor shut off.

∞ Not to be used for lifting.

Also available in E 110 CE



Electric Pump

HYDRAULIC PE60 SERIES

Post Tensioning

0,9 l/min

Two-Speed

Compact, light weight pump.
Excellent choice for rugged
applications and low voltage
starting.

PUMPS

- Long, trouble free life in the most demanding work environments. For operating single- or double-acting cylinders, or stressing jacks.
- Powered by 0,84 KW, 220 volt, 60/50 Hz single phase motor. Starts under load, even at the reduced voltages at construction sites.
- Optional fan-driven external oil cooler includes rollover guard.
- Insulated carrying handle.
- Integral 102 mm fluid-filled pressure gauge with steel bezel complies with ASME B40.1 Grade A. With 0 to 700 bar pressure range in 7 bar increments.
- Sealed 4,34 l (usable) reservoir. Reservoir drain port is standard.
- Standard oil level sight gauge for accurate oil level monitoring.



PE604T
w/cooler

- External spin-on filter removes contaminants from circulating oil to maximize pump, valve and cylinder/tool life.

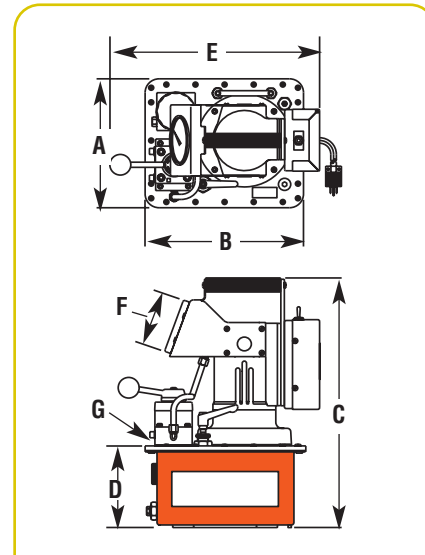
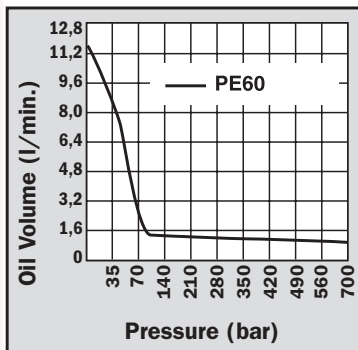

Pump No.	Max. Pressure Output bar	rpm	Noise level Idle and 700 bar (dBA)	Amp Draw at 700 bar (A)	Oil Del. (l/min at..)				A (mm)	B (mm)	C (mm)	D (mm)	E (mm)	F (mm)	G (in)	Prod. Wt. w/Oil (kg)
					0 bar	50 (50)	350 bar	700 bar								
PE604T-220	700	12.000	80/85	13	11,3	7,1	1,2	0,9	263,5	301,6	457,2	152,4	381	101,6	3/8 NPTF	27,2
PE604PT-220	700	12.000	80/85	13	11,3	7,1	1,2	0,9	263,5	301,6	457,2	152,4	381	101,6	3/8 NPTF	27,7

NOTE: Unloading pressure is 70 bar.
Consult factory for PE60 pump models with other control and valve options.



PE604T

700 bar



PUMPS



The PE60 used for pre-stressing.



Description	Order No.	Valve Type	Valve No.	Valve Function	Control Switch	Motor	Reservoir Usable (l)
Single-Acting, Spring Seat, Stressing Jack or Double-Acting	0,84 kW pump with 4,73 l reservoir & valve for double-acting systems. PE604T	4-Way 3-position	9500	Advance Hold Return	On/Off/Pulse	0,84 kW, 220 VAC 50 Hz, Single Phase	4,34
Single-Acting or Double-Acting Power Seat, Stressing Jacks Only	PE604T, except has special valve for post tensioning application only. PE604PT	4-Way 3-position	9628 Model C	Advance Hold Sequenced Return	On/Off/Pulse	0,84 kW, 220 VAC 50 Hz, Single Phase	4,34
OPTIONAL							
252511: Oil cooler kit for PE604T or PE604PT, 115 VAC. Weight 2,7 kg. 252512: Oil cooler kit for PE604T or PE604PT, 220 VAC. Weight 2,7 kg.							



Electric Pump HYDRAULIC PQ60 SERIES

Up to 200 ton
0,8 l/min

Pump designed specifically for heavy duty, extended cycle operation.

PUMPS

- For operating single- or double-acting cylinders.
- Metal shroud keeps dirt and moisture out of motor and electrical components.
- Electrical shut-down feature prevents unintentional restarting of motor following an electrical service interruption.
- Internal relief valve limits pressure to 700 bar. External relief valve is adjustable from 70 to 700 bar.
- Pumps operate below maximum OSHA noise limitation (74-76 dBA).
- Start and operate under full load, even with voltage reduced 10%.



PQ603

700 bar

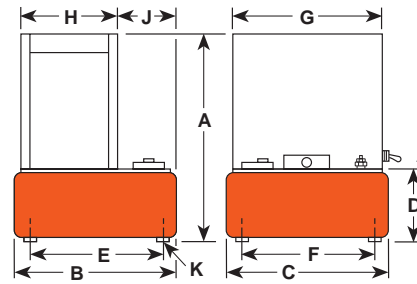
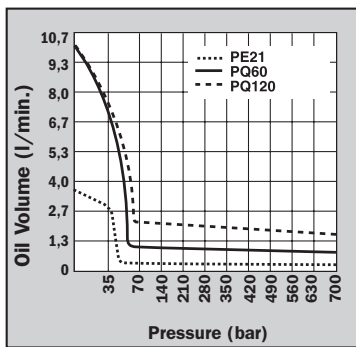

Pump No.	Max. Pressure Output bar	rpm	Noise level at Idle and 700 bar (dBA)	Amp Draw at 700 bar (A)	7 bar	Oil Del. (l/min at..)			A (mm)	B (mm)	C (mm)	D (mm)	E (mm)	F (mm)	G (mm)	H (mm)	J (mm)	K*** (in)	Prod. Wt. w/Oil (kg)
						70 bar	350 bar	700 bar											
PQ60 Series	700	1.437	74/76*	See Chart (following page)	9,7	0,9	0,9	0,8	638	362	394	184	308	338	373	237	122,2	1/2-20 UNF	76,6**

* Measured at a 0,9 m distance, all sides.

** Total weight with oil and 3-way solenoid valve. Subtract 4,5 kg to obtain weight of pump with manual valve.

*** For 50,8 mm dia. swivel casters, order (4) No. 10494.



PQ604



PQ604S



Hydraulic Machine Press Operation.

For use with Cyl. Type	Description	Order No.	Valve Type	Valve No.	Valve Function	Max. Amp Draw at 700 bar (A)	Motor	Reservoir Usable (l)
Single-Acting	1,49 KW pump with 21,6 l reservoir and manual valve,	PQ603-50-220	3-Way	9520*	Advance Hold Return	115V - 22 amps 230V - 11 amps	1,49 KW, 220 Volt 50 Hz, Single	20
Single-Acting	PQ603-50-220, except has solenoid operated remote valve.	PQ603S-50-220	3-Way	9599†	Advance Hold Return	115V - 22 amps 230V - 11 amps	1,49 KW, 220 Volt 50 Hz, Single	20
Double-Acting	1,49 KW pump with 21,6 l reservoir and manual valve.	PQ604-50-220	4-Way	9506*	Advance Hold Return	115V - 22 amps 230V - 11 amps	1,49 KW, 220 Volt 50 Hz, Single	20
Double-Acting	PQ604-50-220, except has solenoid operated remote valve.	PQ604S-50-220	4-Way	9512†	Advance Hold Return	115V - 22 amps 230V - 11 amps	1,49 KW, 220 Volt 50 Hz, Single	20

* Manual valve. Pump is equipped with RUN/OFF/PULSE switch for control of motor.

† Solenoid valve. Pump is equipped with a remote control switch with 3,1 m cord.

‡ Some Power Team pumps are available in special configurations not listed in this catalog. Power Team can "Assemble to Order" pumps with special seals, voltages, valves, relief valve settings, etc. For your special requirements please consult your local distributor or the Power Team factory.



Electric Pump HYDRAULIC PQ120 SERIES

Up to 400 Ton 1,6 l/min

Low speed, high torque pump designed specifically for heavy duty, extended cycle operation. Ideal for press operation.

PUMPS

- Start and operate under full load, even with voltage reduced 10%.
- Electrical shut-down feature prevents unintentional restarting of motor following an electrical service interruption.
- Internal relief valve limits pressure to 700 bar. External relief valve is adjustable from 70 to 700 bar.
- Pump prewired at factory with a 2,24 KW, 380 volt, 50 Hz. 3 Phase motor. Other electrical configurations are available. See ordering information on the following page.
- 24 volt control circuits on units with remote controls for added user/operator safety.
- 2,24 KW(3 phase) motor with thermal overload protection. Motor starter and heater element supplied as standard equipment; no hidden charges!
- Metal shroud keeps dirt and moisture out of motor and electrical components.
- Pumps operate below maximum OSHA noise limitation.



PQ1203

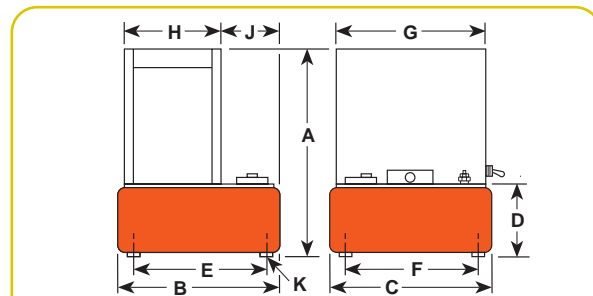
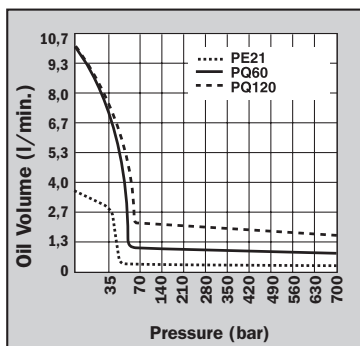

Pump No.	Max. Pressure Output bar	Noise level at Idle and 700 bar (dB(A))	Amp Draw at 700 bar (A)	Oil Del. (l/min at..)				Dimensions						Prod. Wt. w/Oil (kg)				
				7 bar	70 bar	350 bar	700 bar	A (mm)	B (mm)	C (mm)	D (mm)	E (mm)	F (mm)		G (mm)	H (mm)	J (mm)	K*** (in)
PQ120-Series	700	73/78*	See Chart Above	9,7	2,1	1,7	1,6	638	362	394	184	308	338	373	237	122,2	1/2-20 UNF	74,3**

* Measured at a 0,9 m distance, all sides.

** Total weight with oil and 3-way solenoid valve. Subtract 4,5 kg to obtain weight of pump with manual valve.

*** For 50,8 mm dia. swivel casters, order (4) No. 10494.



PQ1204



PQ1204S

700 bar



For use with cyl.-type	Description	Order No.	Valve Type	Valve No.	Valve Function	Motor	Reservoir Usable (l)
Single-acting	2,24 KW pump with 21,6 l reservoir and manual valve.	PQ1203-E380	3-Way	9520*	Advance Hold Return	2,24 KW, 400 Volt 50 Hz, 3 Phase	20
Single-acting	PQ1203-50-380, except has solenoid operated remote valve.	PQ1203S-E380	3-Way	9599†	Advance Hold Return	2,24 KW, 400 Volt 50 Hz, 3 Phase	20
Double-acting	2,24 KW pump with 21,6 l reservoir and manual valve.	PQ1204-E380	4-Way	9506*	Advance Hold Return	2,24 KW, 400 Volt 50 Hz, 3 Phase	20
Double-acting	PQ1204-50-380, except has solenoid operated remote valve.	PQ1204S-E380	4-Way	9512†	Advance Hold Return	2,24 KW, 400 Volt 50 Hz, 3 Phase	20

* Manual valve. Pump is equipped with RUN/OFF/PULSE switch for control of motor.

† Solenoid valve. Pump is equipped with a remote control switch with 3,1 m cord.

‡ Some Power Team pumps are available in special configurations not listed in this catalog. Power Team can "Assemble to Order" pumps with special seals, voltages, valves, relief valve settings, etc. For your special requirements please consult your local distributor or the Power Team factory.



Electric Pump

HYDRAULIC PE400 SERIES

Up to 1,000 Ton
5,6 l/min

High tonnage double-acting cylinders, Single or multiple cylinder applications. Up to 1,000 Tons

PUMPS

- Two-speed high output pump delivers up to 16 l/min of oil.
- Low noise level of 73-80 dBA.
- Integral electrical shut-down feature prevents unintentional restarting of motor following an electrical service interruption. Over-current protection prevents damage to motor as a result of overheating.
- "Stop" and "Start" control buttons are 24 volt. PE4004 has a 4-way/3-position manual valve. The PE4004S has a 4-way/3-position solenoid valve with a 24 volt remote hand switch.
- External pressure relief valve is adjustable from 100 to 700 bar.
- Heavy duty 50,8 mm dia. casters assure easy maneuvering.
- 75,7 l (62,8 l usable) reservoir has a low oil level sight gauge.
- Powered by a dual voltage 7,46 KW, 3 phase, 1,437 rpm motor.
- 3 phase motor has all the electrical components necessary to operate the pump. The customer has no hidden charges when making purchase.
- Deliver 16 l/min. of oil at 15 bar, 5,6 l/min. of oil at 700 bar.

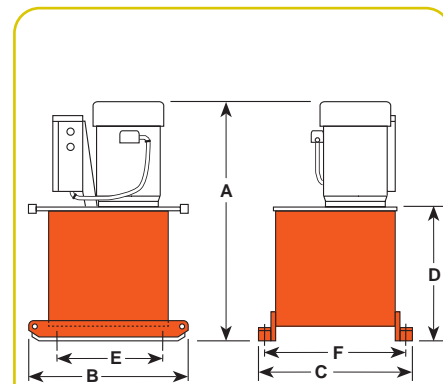
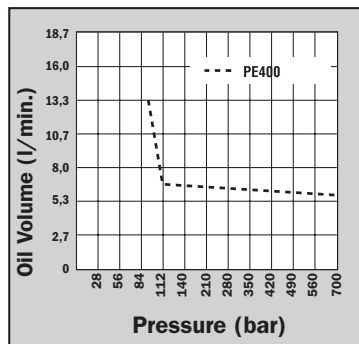

Pump No.	Max. Pressure Output bar	rpm	Noise level at Idle and 700 bar (dBA)	Amp Draw at 700 bar (A)	Oil Del. (l/min at..)				A* (mm)	B (mm)	C (mm)	D (mm)	E Caster Mfg. (mm)	F Caster Mfg. (mm)	Prod. Wt. w/Oil (kg)
					15 bar	90 bar	350 bar	700 bar							
PE4004-50-380	700	1.437	73/80	6	16	14	6	5,6	924	635	610	540	394	546	223
PE4004S-50-380	700	1.437	73/80	6	16	14	6	5,6	924	635	610	540	394	546	229

* Add 127 mm and 3,6 kg when casters are mounted. (Units are supplied with four 102 mm dia. swivel casters.)



PE4004S pump and RD3006 cylinder used in a special press which repairs damaged chain links for the shipping industry.



PE4004S

700 bar

For use with cyl.-type	Description	Order No.	Valve Type	Valve No.	Valve Function	Motor††	Reservoir Usable (l)
Double-acting	7,46 KW pump with 75,5 l reservoir and manual valve.	PE4004-E380	4-Way	9506	Advance Hold Return	7,46 KW, 400 volt 50 Hz, 3 Phase	62,8†
Double-acting	PE4004, except has solenoid operated remote valve.	PE4004S-E380	4-Way	9512**	Advance Hold Return	7,46 KW, 400 volt 50 Hz, 3 Phase	62,8†

** Solenoid valve with remote control.

† Usable oil is calculated with oil fill at recommended level at 57 mm below cover plate.

†† PE400 series available in 220/380V, 50Hz and 460V, 50Hz. Please specify when ordering. Example: PE4004-50-380 or for 460 V PE4004-460.

NOTE: Valves for spring return cylinders are available upon request. Consult the factory.

