

Suction Filters

**AS 010 · AS 025 · AS 040
AS 060 · AS 080 · AS 100
AS 150**

- In Tank mounting
- Connection up to G2½
- Nominal flow rate up to 350 l/min

Description

Application

In the suction line of pumps of hydraulic or lubricating circuits.

Performance features

Protection against malfunction: By full-flow filtration in the suction line, particularly the pumps are protected from coarse dirt particles that have remained in the system after manufacture or repair, or enter the system when it is filled with oil.

Special features

The robust construction with end caps, inner core, and mesh screen material, all out of metal, offers the following advantages:

- Maximum reliability at increased operating temperatures
- Enormous shock and vibration resistance

Construction

Flow direction from outside to centre. The star-shaped pleating of the filter material results in:

- large filter surfaces
- low pressure drop
- long service life

Filter maintenance

- Cleaning in ultrasonic bath for a few minutes.
As an alternative, put suction filter in cleaning agent for approx. 15 minutes and remove dirt from the outside using a brush.
 - Then flush with fresh cleaning fluid from the inside to the outside.
 - Blow out with compressed air from the inside to the outside.
- In any case, be careful that no dirt enters the inner side (clean oil side) of the suction filter.

Selection Chart

Part No.	Nominal flow	Pressure drop see Diagram D	Filter fineness	Filter surface	Cracking pressure of by-pass	Connection B	Diameter D	Length L ₁	Length L ₂	Dimension K	Symbol	Weight	Remarks
1	2	3	4	5	6	7	8	9	10	11	12	13	14
	l/min		µm	cm ²	bar		mm	mm	mm	mm		kg	
AS 010-00	15	D1/1	100 S	155	-	G½	45	82	60	27	1	0,13	-
AS 025-01	35	D1/2	100 S	420	-	G¾	69,5	91	75	36	1	0,24	-
AS 040-01	60	D1/4	100 S	650	-	G1	69,5	133	117	41	1	0,30	-
AS 040-71	60	D1/3	100 S	650	- 0,3	G1	69,5	133	117	41	2	0,30	-
AS 060-01	90	D2/1	100 S	1030	-	G1¼	69,5	205	185	50	1	0,42	-
AS 080-01	120	D2/2	100 S	1320	-	G1½	100	182	165	70	1	0,50	-
AS 080-81	120	D2/2	100 S	1400	- 0,3	G1½	100	182	165	70	2	0,50	-
AS 100-01	200	D2/4	100 S	2300	-	G2	100	213	196	70	1	0,60	-
AS 100-81	150	D2/3	100 S	1750	- 0,3	G2	100	213	196	70	2	0,60	-
AS 150-01	350	D2/5	100 S	2300	-	G2½	150	191	165	ø 82	1	1,40	-

Remarks:

The filter listed in this chart are standard filters. Other designs, e.g. other filter finenesses or magnetic system, available on request.

Diagrams

Δp -curves for filters in Selection Chart, column 3

D1 Pressure drop as a function of the **flow volume** at $v = 35 \text{ mm}^2/\text{s}$

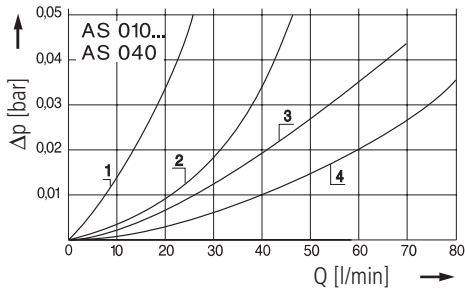

Pressure drop as a function of the **kinematic viscosity** at nominal flow

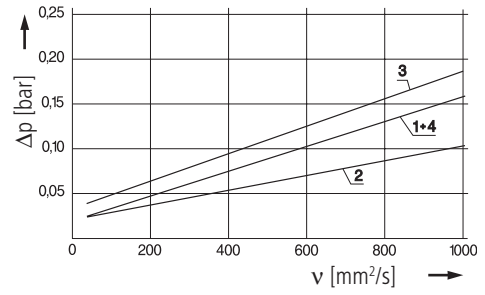

D2 Pressure drop as a function of the **flow volume** at $v = 35 \text{ mm}^2/\text{s}$

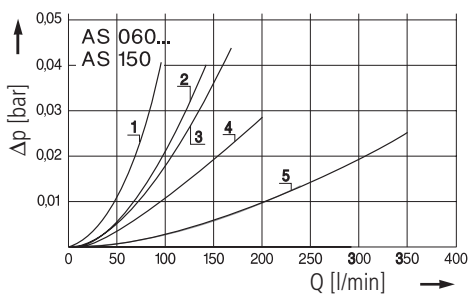

Pressure drop as a function of the **kinematic viscosity** at nominal flow

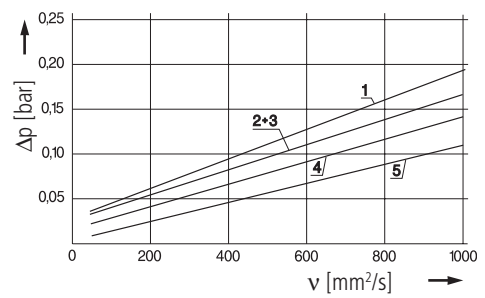

Dimensions

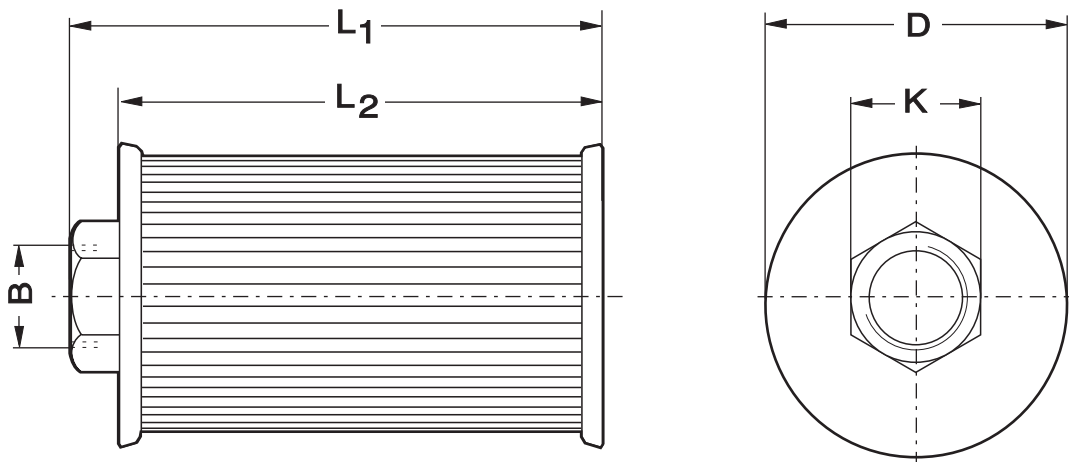

Symbols

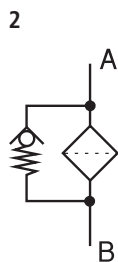

Characteristics

Nominal flow rate

Up to 350 l/min (see Selection Chart, column 2)
The nominal flow rates indicated by ARGO-HYTOS are based on the following features:

- Pressure drop $\Delta p < 0,035$ bar at $v = 35$ mm²/s
- closed by-pass valve at $v \leq 200$ mm²/s
- flow velocity in the connection lines $\leq 1,5$ m/s

Connection

Threaded ports according to ISO 228 or DIN 13. Sizes see Selection Chart, column 7 (other port threads on request).

Filter fineness

100 μ m

Hydraulic fluids

Mineral oil and biodegradable fluids (HEES or HETG, see info-sheet 00.20)

Temperature range

- 30 °C ... + 100 °C (temporary - 40 °C ... + 120 °C)

Materials

- AS 010-00 / AS 025-01 / AS 040-01 / AS 150-01
End caps out of steel,
support mesh out of steel, zinc plated,
filter mesh out of stainless steel (1.4301)
- AS 060-01 / AS 080-01 / AS 100-01
End cap with hexagon out of aluminum,
bottom end cap out of steel,
support mesh out of steel, zinc plated,
filter mesh out of stainless steel (1.4301)

- AS 040-71
End caps out of steel,
filter mesh out of stainless steel (1.4301)
- AS 080-81 / AS 100-81
End cap with hexagon out of aluminum,
bottom end cap out of steel,
filter mesh out of stainless steel (1.4301)

Viscosity at nominal flow rate

- at operating temperature: $v < 60$ mm²/s
- start-up viscosity: v_{\max} equivalent to the permitted pump inlet pressure (refer to diagram D), Δp to be determined as a function of the viscosity (take pressure loss in connection lines into account!)
- during initial operation of units equipped with by-pass valve:
The recommended starting viscosity can be read from the Diagram D (pressure drop as a function of the kinematic viscosity) as follows: Find the 70% Δp of the cracking pressure of the by-pass valve on the vertical axis. Draw a horizontal line so that it intersects the Δp curve at a point. Read this point on the horizontal axis for the viscosity.

Mounting position

Optional; versions equipped with bypass valve preferably in horizontal position. Under all operating conditions (min. oil level, max. inclination) the suction must occur under the oil level.

Quality Assurance

Quality management according to DIN EN ISO 9001

To ensure constant quality in production and operation, ARGO-HYTOS filter elements undergo strict controls and tests according to the following DIN and ISO standards:

- DIN ISO 2941** Verification of collapse/burst resistance
- DIN ISO 2943** Verification of material compatibility with fluids
- DIN ISO 3724** Verification of flow fatigue characteristics

ISO 2942 ISO 3968 ISO 16889

Verification of fabrication integrity (Bubble Point Test)
Evaluation of pressure drop versus flow characteristics
Multi-Pass-Test (evaluation of filter fineness and dirt-holding capacity)

Various quality controls during the production process guarantee the leakfree function and solidity of our filters.

Our engineers will be glad to advice you in questions concerning filter application, selection as well as the cleanliness class of the filtered medium attainable under practical operating conditions.

Illustrations may sometimes differ from the original. ARGO-HYTOS is not responsible for any unintentional mistake in this specification sheet.



We produce fluid power solutions

ARGO-HYTOS GMBH · Industriestraße 9 · D-76703 Kraichtal

Tel: +49 7250 76-0 · Fax: +49 7250 76-199 · info.de@argo-hytos.com · www.argo-hytos.com

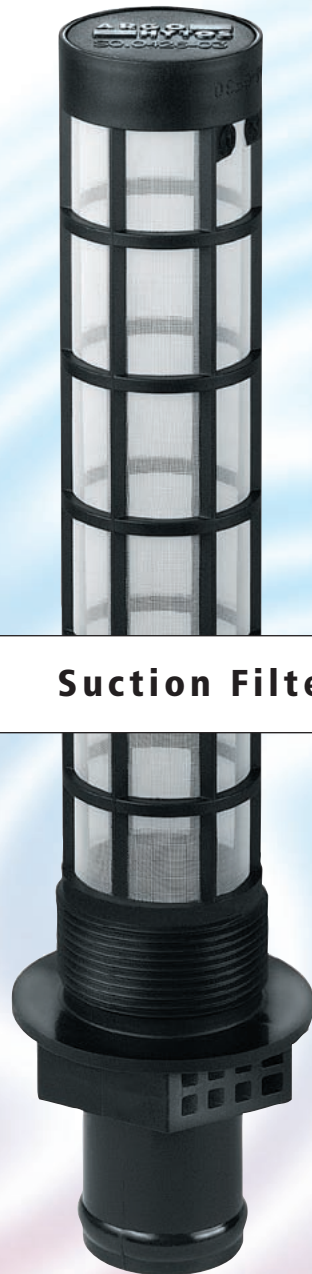

Suction Filters

S0.0426 · S0.0638

- In Tank mounting
- Hose connection up to DN 60
- Nominal flow rate up to 160 l/min

Diagrams

Δp -curves for filters in Selection Chart, column 3

D1 Pressure drop as a function of the **flow volume**
at $v = 35 \text{ mm}^2/\text{s}$

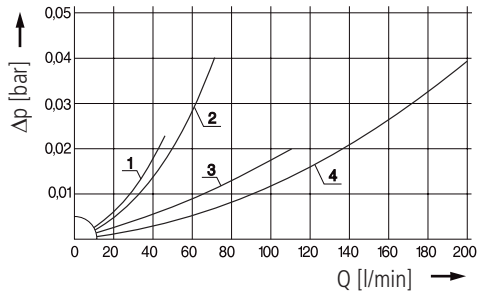

Pressure drop as a function of the **kinematic viscosity**
at nominal flow

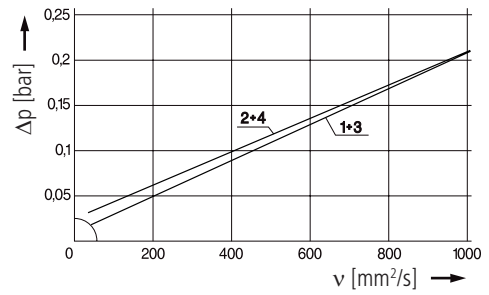

Dimensions

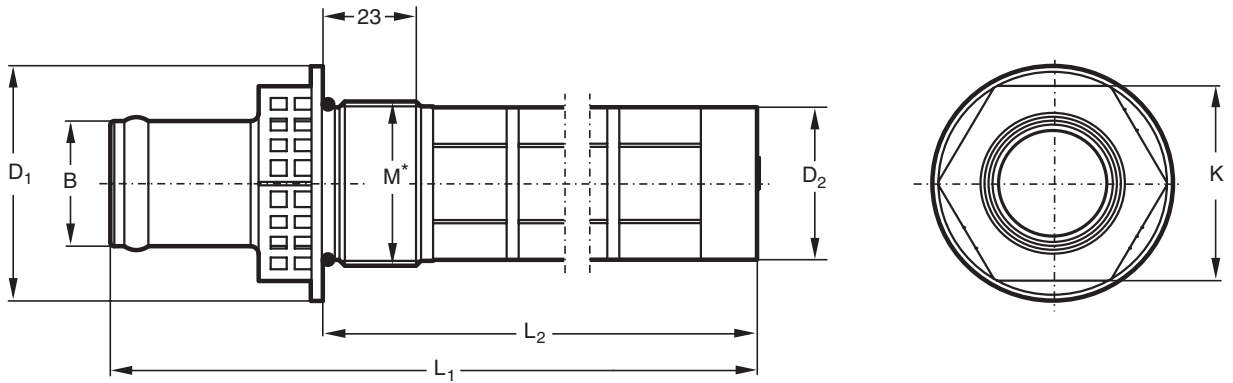

Recommended
port sizes

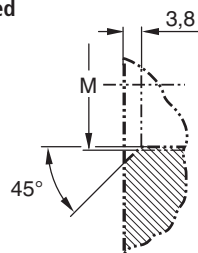

* The thread dimensions do not exactly conform to the DIN ISO standard thread (functioning with the DIN ISO standard thread is guaranteed)

Symbols

1



2

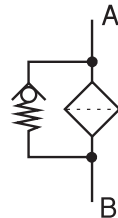

Characteristics

Nominal flow rate

Up to 160 l/min (see Selection Chart, column 2)

The nominal flow rates indicated by ARGO-HYTOS are based on the following features:

- Pressure drop $\Delta p < 0,035$ bar at $v = 35$ mm²/s
- Pressure drop $\Delta p \leq 0,25$ bar at $\frac{1}{3}$ of the nominal flow rate and $v = 4000$ mm²/s (~ HLP 46 at -20 °C)
- flow velocity in the connection lines $\leq 1,5$ m/s

Connection

Fittings for hoses up to DN 60. Sizes see Selection Chart, column 6 (other port threads on request).

Filter fineness

135 µm, 280 µm

Hydraulic fluids

Mineral oil and biodegradable fluids (HEES or HETG, see info-sheet 00.20)

Temperature range

-30 °C ... +80 °C (temporary -40° ... +100 °C)

Materials

Corpus: Polyamide, GF reinforced
Screw-on cap: Polyamide, GF reinforced
Seal: NBR (Viton on request)
Filter mesh: Polyethylene terephthalate

Viscosity at nominal flow rate

- at operating temperature: $v < 60$ mm²/s
- start-up viscosity: v_{max} equivalent to the permitted pump inlet pressure (refer to diagram D), Δp to be determined as a function of the viscosity (take pressure loss in connection lines into account!)

Mounting position

Optional, preferably in horizontal position.

Under all operating conditions (min. oil level, max. inclination) the suction must occur under the oil level.

Quality Assurance

Quality management according to DIN EN ISO 9001

To ensure constant quality in production and operation, ARGO-HYTOS filter elements undergo strict controls and tests according to the following DIN and ISO standards:

DIN ISO 2941 Verification of collapse/burst resistance
DIN ISO 2943 Verification of material compatibility with fluids
DIN ISO 3724 Verification of flow fatigue characteristics

ISO 2942

ISO 3968

ISO 16889

Verification of fabrication integrity (Bubble Point Test)
Evaluation of pressure drop versus flow characteristics
Multi-Pass-Test (evaluation of filter fineness and dirt-holding capacity)

Various quality controls during the production process guarantee the leakfree function and solidity of our filters.

Our engineers will be glad to advice you in questions concerning filter application, selection as well as the cleanliness class of the filtered medium attainable under practical operating conditions.

Illustrations may sometimes differ from the original. ARGO-HYTOS is not responsible for any unintentional mistake in this specification sheet.



We produce fluid power solutions

ARGO-HYTOS GMBH · Industriestraße 9 · D-76703 Kraichtal

Tel: +49 7250 76-0 · Fax: +49 7250 76-199 · info.de@argo-hytos.com · www.argo-hytos.com