



Suction Filters

ES 074 · ES 094

- Tank top mounting
- Connection up to G1¼
- Nominal flow rate up to 80 l/min

Description

Application

To be installed in the suction line of the pumps of hydraulic systems resp. upstream of the charge pumps of hydrostatic drives.

Performance features

Protection against wear: By means of filter elements that, in full-flow filtration, meet even the highest demands regarding cleanliness classes.

Protection against malfunction: By means of full-flow filtration in the system return, the pumps above all are protected from dirt particles remaining in the system after assembly, repairs, or which are generated by wear or enter the system from outside.

Special features

By-pass valve: The location close to the suction inlet prevents dirt particles retained by the filter element from entering into the clear oil side.

Filter element locking valve: Ensures that dirt accumulated in the filter element is removed together with the element and cannot return to the tank.

Foot valve: When the screw-on cap is removed for maintenance, the foot valve closes automatically. This makes it possible to service the filter even if it is submerged below the oil level in a full tank.

Filter elements

Flow direction from centre to outside. The star-shaped pleating of the filter material results in:

- large filter surfaces
- low pressure drop
- high dirt-holding capacities
- long service life

In filters with a magnetic system, the ferromagnetic particles in the fluid pass first through a strong magnetic field and are separated.

Filter maintenance

By using a clogging indicator the correct moment for maintenance is stated and guarantees the optimum utilization of the filter life.

Materials

Screw-on cap: Polyester, GF reinforced
Filter head: Aluminium alloy
Filter bowl: Steel
Seals: NBR (Viton on request)
EXAPOR®-inorganic microfibre web
Filter media: Paper-cellulose web, impregnated with resin
Stainless steel wire mesh (1.4301)

Accessories

Electrical and optical clogging indicators are available.
Dimensions and technical data see catalogue sheet 60.20.

Characteristics

Nominal flow rate

Up to 80 l/min (see Selection Chart, column 2)

The nominal flow rates indicated by ARGO-HYTOS are based on the following features:

- closed by-pass valve at $v \leq 200 \text{ mm}^2/\text{s}$
- element service life > 1000 operating hours at an average fluid contamination of 0,07 g per l/min flow volume
- flow velocity in the connection lines $\leq 1,5 \text{ m/s}$
If units not equipped with a bypass valve are used in hydrostatic drives, the recommendations regarding their technical application given on catalogue sheet 10.310 should be observed.

Connection

Threaded ports according to ISO 228 or DIN 13. Sizes see Selection Chart, column 6 (other port threads on request)

Filter fineness

16 $\mu\text{m(c)}$... 60 $\mu\text{m(c)}$

β -values according ISO 16889

(see Selection Chart, column 4 and Diagram Dx)

Dirt-holding capacity

Values in g test dust ISO MTD according to ISO 16889

(see Selection Chart, column 5)

Hydraulic fluids

Mineral oil and biodegradable fluids
(HEES or HETG, see info-sheet 00.20)

Temperature range

- 30 °C ... + 100 °C (temporary - 40 °C ... + 120 °C)

Viscosity at nominal flow rate

- at operating temperature: $v < 60 \text{ mm}^2/\text{s}$
- start-up viscosity: determine v_{max} , observing the permissible pressure at the pump inlet according to diagram D; determine Δp as a function of the viscosity (take into account the pressure loss in the connecting lines!)
- on initial operation of units equipped with a bypass valve:

The recommended starting viscosity can be read from the Diagram D (pressure drop as a function of the kinematic viscosity) as follows: Find the 70% Δp of the cracking pressure of the by-pass valve on the vertical axis. Draw a horizontal line so that it intersects the Δp curve at a point. Read this point on the horizontal axis for the viscosity.

Mounting position

Vertical mounting to be preferred, suction opening pointing downwards, versions equipped with foot valve for horizontal mounting also.

Diagrams

Δp -curves for complete filters in Selection Chart, column 3

D1 Pressure drop as a function of the **flow volume**
at $v = 35 \text{ mm}^2/\text{s}$ (0 = casing empty)

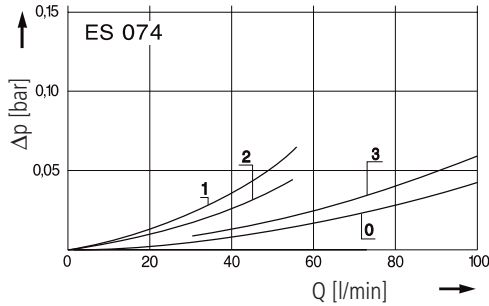

Pressure drop as a function of the **kinematic viscosity**
at nominal flow

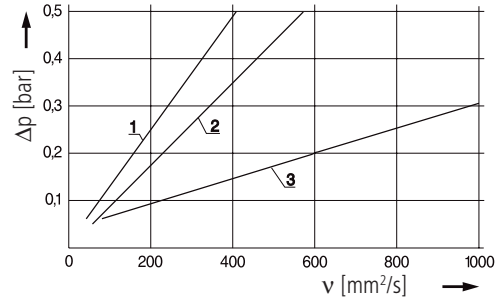

D2 Pressure drop as a function of the **flow volume**
at $v = 35 \text{ mm}^2/\text{s}$ (0 = casing empty)

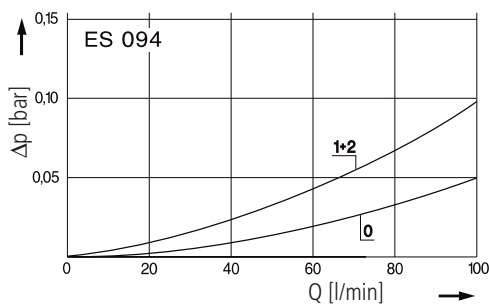

Pressure drop as a function of the **kinematic viscosity**
at nominal flow

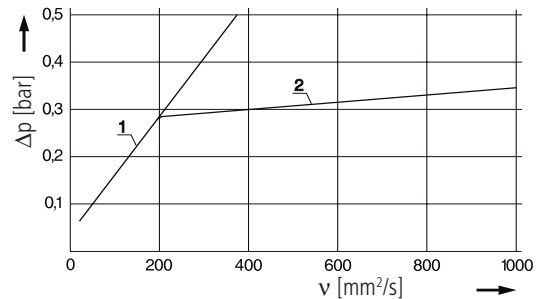

Filter fineness curves in Selection Chart, column 4

Dx Filtration ratio β as a function of particle size x obtained by the
Multi-Pass-Test according to ISO 16889

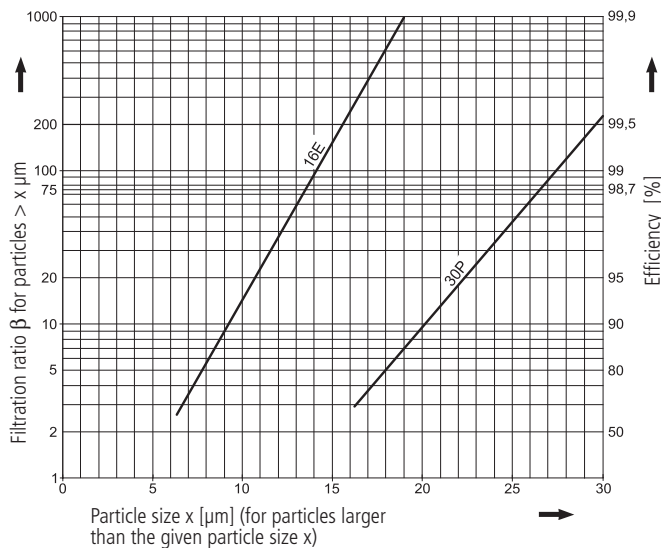

The abbreviations represent the following β -values resp. finenesses:

For EXAPOR®- and Paper elements:

16 E = $\bar{\beta}_{16(d)} = 200$ EXAPOR®

30 P = $\bar{\beta}_{30(d)} = 200$ Paper

Based on the structure of the filter media of the 30 P paper elements, deviations from the printed curves are quite probable.

For screen elements:

40 S = screen material with mesh size 40 μm

60 S = screen material with mesh size 60 μm

100 S = screen material with mesh size 100 μm

Tolerances for mesh size according to DIN 4189.

For special applications, finenesses differing from these curves are also available by using special composed filter material.

Selection Chart

Part No.	Nominal flow	Pressure drop see Diagram D /curve no.	Filter fineness see Diagram Dx	Dirt-holding capacity	Filter surface in ()	Connection B	Cracking pressure of by-pass	Foot valve	Symbol	Replacement filter element Part No.	Weight	Remarks
1	2	3	4	5	6	7	8	9	10	11	12	
ES 074-6801	35*	D1/1	16 E	18	G1¼	-	•	2	V2.0923-07	2,4	-	
ES 074-6110	45*	D1/1	30 P	23	G1	-	-	1	P2.0923-01	2,2	-	
ES 074-6120	45*	D1/2	30 P	23	G1¼	-	-	1	P2.0923-01	2,2	-	
ES 074-6121	45*	D1/1	30 P	23	G1	-	•	2	P2.0923-01	2,4	-	
ES 074-6141	45*	D1/2	30 P	23	G1¼	-	•	2	P2.0923-01	2,4	-	
ES 074-0001	80	D1/3	60 S	(1540 cm ²)	G1¼	-0,25	•	6	S2.0920-10	2,4	with magnetic system	
ES 094-6801	55*	D2/1	16 E	26	G1¼	-	•	2	V2.0933-08	3,2	-	
ES 094-6110	70*	D2/1	30 P	34	G1¼	-	-	1	P2.0933-01	3,0	-	
ES 094-6111	70*	D2/1	30 P	34	G1¼	-	•	2	P2.0933-01	3,2	-	
ES 094-6121	70	D2/2	30 P	34	G1¼	-0,25	•	4	P2.0933-01	3,2	-	

All filters are delivered with a plugged clogging indicator connection G¼. As clogging indicators either manometers or vacuum switches can be used. Optional extension pipes adapt the filter length to various tank depths. For ordering of accessories please use the below mentioned codes.

Order example: The filter ES 074-6110 has to be supplied with an extension pipe (EV) for a mounting depth of 400 mm.

Order description: ES 074-6110 / EV 400

Part No. (Basic unit) _____

Extension pipe (2 various lengths are available) _____

EV = 400 / 500 mm (see dimensions and measurements)

For the appropriate clogging indicator see catalogue sheet 60.20.

Remarks:

- The start of the red area respectively the actuating pressure of the vacuum switch has always to be higher than the cracking pressure of the by-pass valve (see Selection Chart, column 7).
- The clogging indicators are optionally available and will then be loosely provided.
- The filters listed in this chart are standard filters. Other designs available on request.

* Those values apply when used in hydrostatic drives and instructions in catalogue sheet 10.310 have to be observed

Dimensions

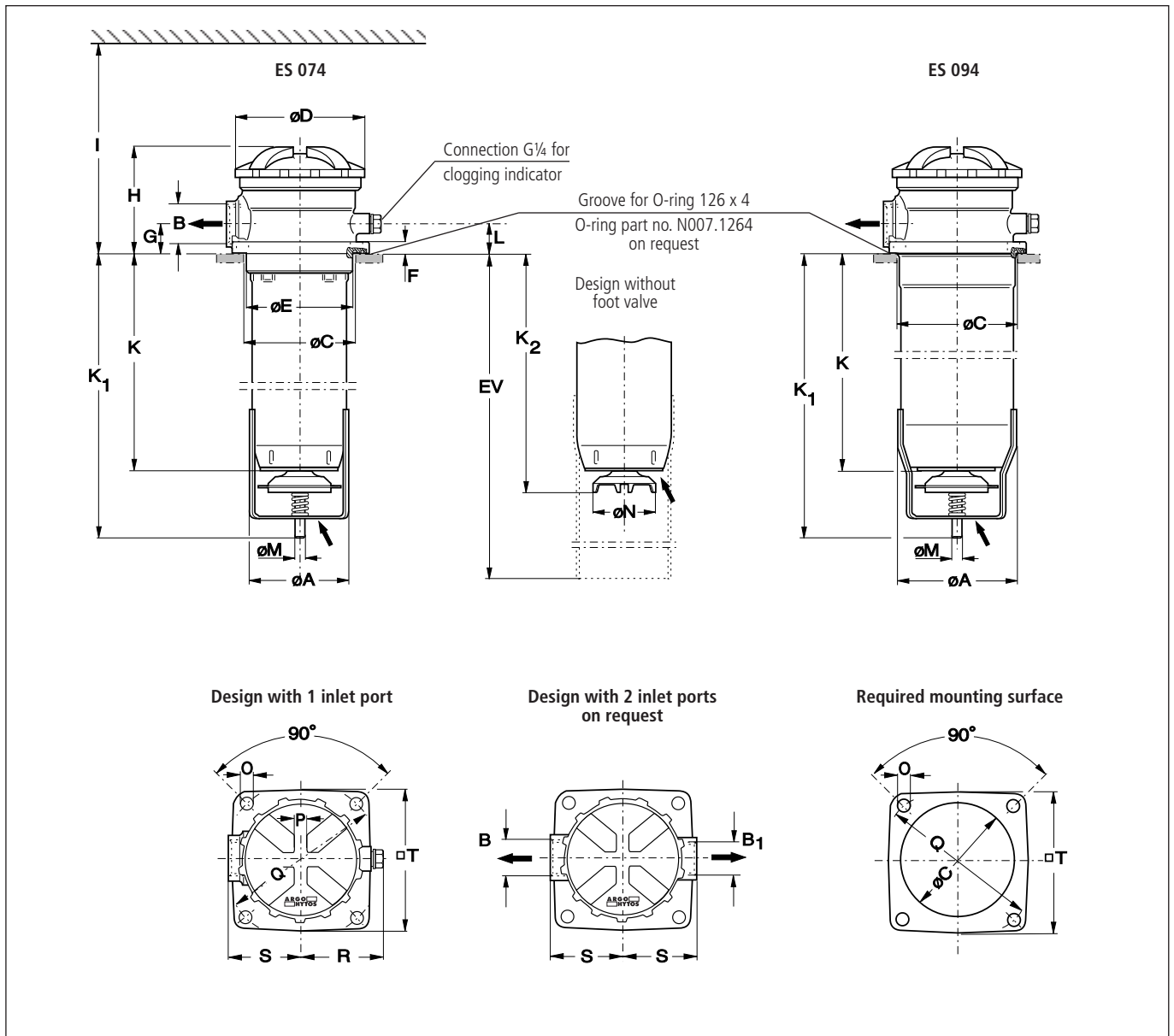

Measurements

Type	A	B	C min./max.	D	E	F	G	H	I	K	K_1	K_2	L	M	N	O	P
ES 074	100	G1, G1 $\frac{1}{4}$	111/121	126,5	110	11,5	32	106	400	198	256	218	35	10	62,5	11	13
ES 094	115	G1 $\frac{1}{4}$	119/121	126,5	-	11,5	32	106	525	305	364	325	35	10	62,5	11	13
Type	Q	R	S	T													
ES 074	165	82,5	76	141													
ES 094	165	76,5	76	141													

Symbols

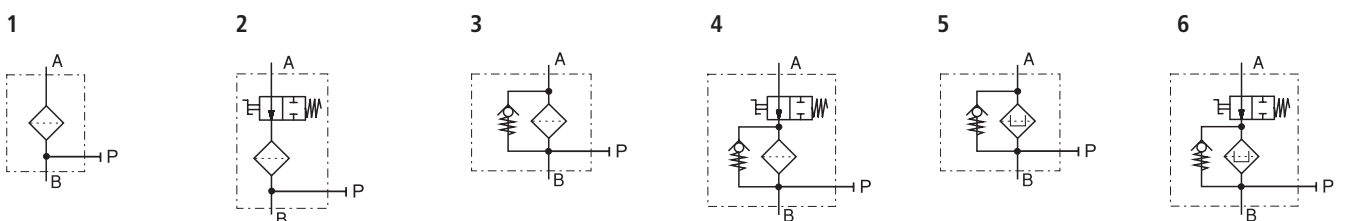

Spare Parts

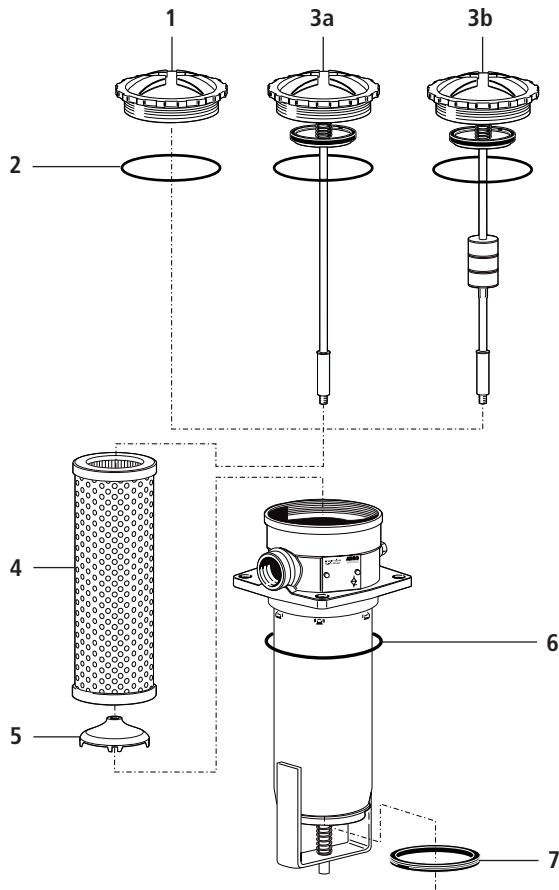

Pos.	Designation	Part No.
1	Screw-on cap with Pos. 2	ES 074.1212
2	O-ring 100 x 4	N 007.1004
3a	Screw-on cap with Pos. 2 ES 074 (without by-pass) ES 094 (without by-pass) ES 094 (with by-pass)	ES 074.1213 ES 094.1212 ES 094.1213
3b	Screw-on cap with Pos. 2 including magnetic system ES 074 (with by-pass)	ES 074.1205
4	Filter element	see Chart / col. 10
5	Valve cone	ES 074.0202
6	O-ring 126 x 4 *	N 007.1264
7	Rubber ring	N 042.7401

* not included in basic equipment

The functions of the complete filters as well as the outstanding features of the filter elements assured by ARGO-HYTOS can only be guaranteed if original ARGO-HYTOS spare parts are used.

Quality Assurance

Quality management according to DIN EN ISO 9001

To ensure constant quality in production and operation, ARGO-HYTOS filter elements undergo strict controls and tests according to the following DIN and ISO standards:

DIN ISO 2941	Verification of collapse/burst resistance
DIN ISO 2943	Verification of material compatibility with fluids
DIN ISO 3724	Verification of flow fatigue characteristics

ISO 2942
ISO 3968
ISO 16889

Verification of fabrication integrity (Bubble Point Test)
Evaluation of pressure drop versus flow characteristics
Multi-Pass-Test (evaluation of filter fineness and dirt-holding capacity)

Various quality controls during the production process guarantee the leakfree function and solidity of our filters.

Our engineers will be glad to advice you in questions concerning filter application, selection as well as the cleanliness class of the filtered medium attainable under practical operating conditions.

Illustrations may sometimes differ from the original. ARGO-HYTOS is not responsible for any unintentional mistake in this specification sheet.



We produce fluid power solutions

ARGO-HYTOS GMBH · Industriestraße 9 · D-76703 Kraichtal

Tel: +49 7250 76-0 · Fax: +49 7250 76-199 · info.de@argo-hytos.com · www.argo-hytos.com

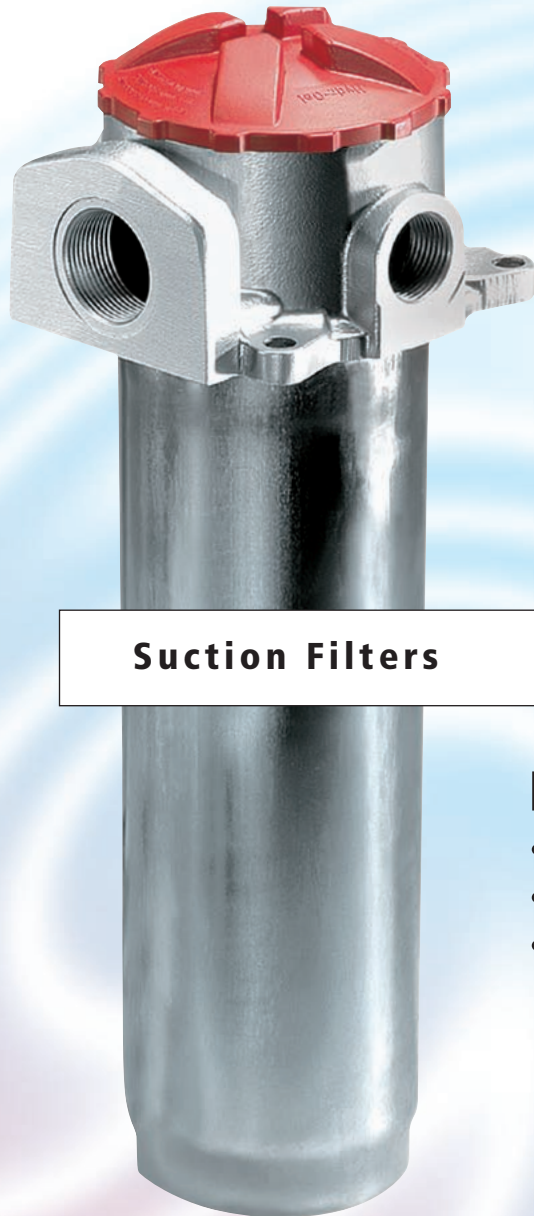

Suction Filters

ES 134 • ES 144

- Tank top mounting
- Connection up to SAE 1¹/₂
- Nominal flow rate up to 130 l/min

Description

Application

To be installed in the suction line of the pumps of hydraulic systems resp. upstream of the charge pumps of hydrostatic drives.

Performance features

Protection

against wear: By means of filter elements that, in full-flow filtration, meet even the highest demands regarding cleanliness classes.

Protection against

malfunction: By means of full-flow filtration in the system return, the pumps above all are protected from dirt particles remaining in the system after assembly, repairs, or which are generated by wear or enter the system from outside.

Special features

By-pass valve: The location close to the suction inlet prevents dirt particles retained by the filter element from entering into the clear oil side.

Filter element

locking valve: Ensures that dirt accumulated in the filter element is removed together with the element and cannot return to the tank.

Foot valve: When the screw-on cap is removed for maintenance, the foot valve closes automatically. This makes it possible to service the filter even if it is submerged below the oil level in a full tank.

Filter elements

Flow direction from centre to outside. The star-shaped pleating of the filter material results in:

- large filter surfaces
- low pressure drop
- high dirt-holding capacities
- long service life

In filters with a magnetic system, the ferromagnetic particles in the fluid pass first through a strong magnetic field and are separated.

Filter maintenance

By using a clogging indicator the correct moment for maintenance is stated and guarantees the optimum utilization of the filter life.

Materials

Screw-on cap: Polyester, GF reinforced

Filter head: Aluminium alloy

Filter bowl: Steel

Seals: NBR (Viton on request)

Filter media: Paper - cellulose web, impregnated with resin
Stainless steel wire mesh (1.4301)

Accessories

Electrical and optical clogging indicators are available. Dimensions and technical data see catalogue sheet 60.20.

Characteristics

Nominal flow rate

Up to 130 l/min (see Selection Chart, column 2)

The nominal flow rates indicated by ARGO-HYTOS are based on the following features:

- closed by-pass valve at $v \leq 200 \text{ mm}^2/\text{s}$
- element service life > 1000 operating hours at an average fluid contamination of 0,07 g per l/min flow volume
- flow velocity in the connection lines $\leq 1,5 \text{ m/s}$
If units not equipped with a bypass valve are used in hydrostatic drives, the recommendations regarding their technical application given on catalogue sheet 10.310 should be observed.

Connection

Threaded ports according to ISO 228 or DIN 13 or SAE-flanges (3000 psi)

Sizes see Selection Chart, column 6 (other port threads on request)

Filter fineness

30 $\mu\text{m(c)}$... 60 $\mu\text{m(c)}$

β -values according to ISO 16889

(see Selection Chart, column 4 and Diagram Dx)

Dirt-holding capacity

Values in g test dust ISO MTD according to ISO 16889

(see Selection Chart, column 5)

Hydraulic fluids

Mineral oil and biodegradable fluids
(HEES or HETG, see info-sheet 00.20)

Temperature range

- 30 °C ... + 100 °C (temporary - 40 °C ... + 120 °C)

Viscosity at nominal flow rate

- at operating temperature: $v < 60 \text{ mm}^2/\text{s}$
- start-up viscosity: determine v_{max} , observing the permissible pressure at the pump inlet according to diagram D; determine Δp as a function of the viscosity (take into account the pressure loss in the connecting lines!)
- on initial operation of units equipped with a bypass valve:

The recommended starting viscosity can be read from the Diagram D (pressure drop as a function of the kinematic viscosity) as follows: Find the 70% Δp of the cracking pressure of the by-pass valve on the vertical axis. Draw a horizontal line so that it intersects the Δp curve at a point. Read this point on the horizontal axis for the viscosity.

Mounting position

Vertical mounting to be preferred, suction opening pointing downwards, versions equipped with foot valve for horizontal mounting also.

Diagrams

Δp -curves for complete filters in Selection Chart, column 3

D1 Pressure drop as a function of the **flow volume**
at $v = 35 \text{ mm}^2/\text{s}$ (0 = casing empty)

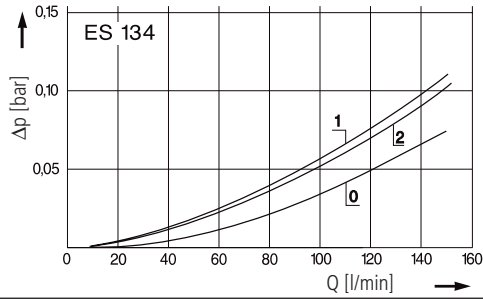

Pressure drop as a function of the **kinematic viscosity**
at nominal flow

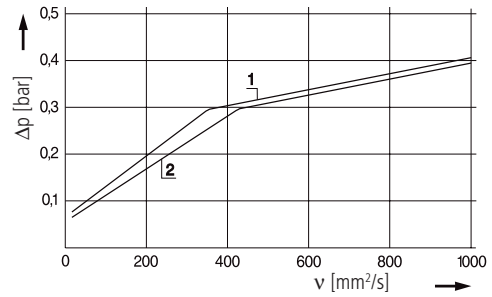

D2 Pressure drop as a function of the **flow volume**
at $v = 35 \text{ mm}^2/\text{s}$ (0 = casing empty)

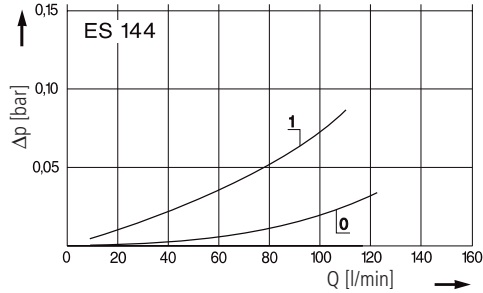

Pressure drop as a function of the **kinematic viscosity**
at nominal flow

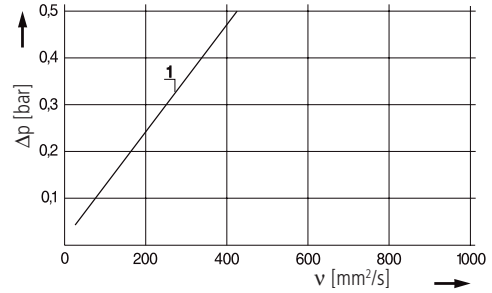

Filter fineness curves in Selection Chart, column 4

Dx Filtration ratio β as a function of particle size x obtained by the
Multi-Pass-Test according to ISO 16889

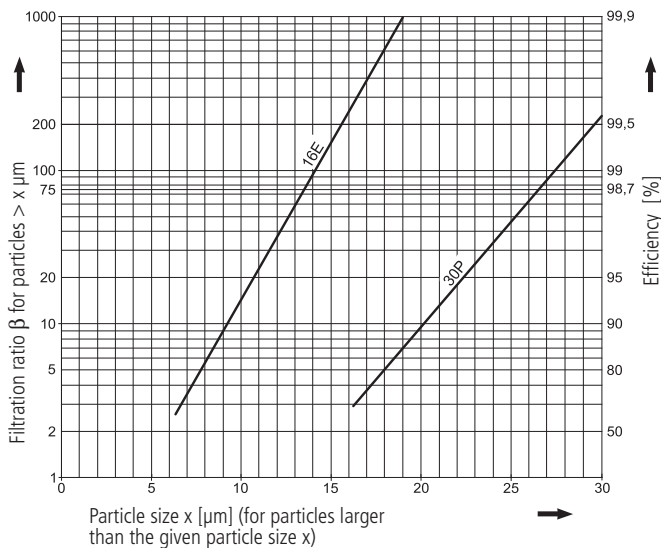

The abbreviations represent the following β -values resp. finenesses:

For EXAPOR®- and Paper elements:

16 E = $\beta_{16(c)} = 200$ EXAPOR®
30 P = $\beta_{30(c)} = 200$ Papier

Based on the structure of the filter media of the 30 P paper elements, deviations from the printed curves are quite probable.

For screen elements:

40 S = screen material with mesh size 40 μm
60 S = screen material with mesh size 60 μm
100 S = screen material with mesh size 100 μm
Tolerances for mesh size according to DIN 4189.

For special applications, finenesses differing from these curves are also available by using special composed filter material.

Dimensions

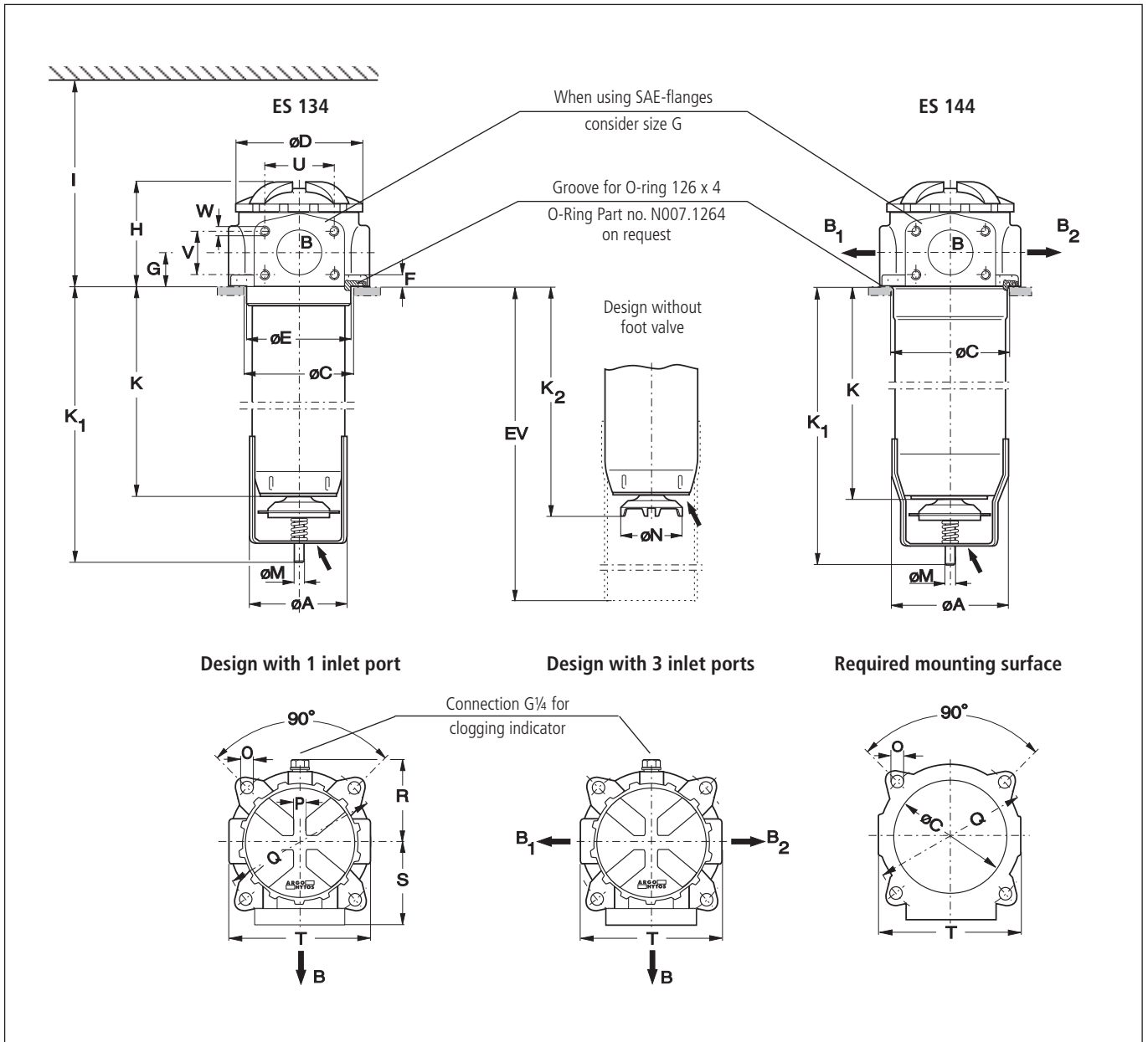

Measurements

Type	A	B	B1	B2	C min./max.	D	E	F	G	H	I	K	K1	K2	L	M	N
ES 134	100	SAE 1½	-	-	111/121	126,5	110	12	32	106	400	198	256	218	-	10	62,5
ES 144	115	G1¼	G1	G1	119/121	126,5	-	12	32	106	525	305	364	325	-	10	62,5
Type	O	P	Q	R	S	T	U	V	W								
ES 134	11,5	13	165	81	82	144	69,8	35,7	M 12								
ES 144	11,5	13	165	81	82	144	69,8	35,7	M 12								

Symbols

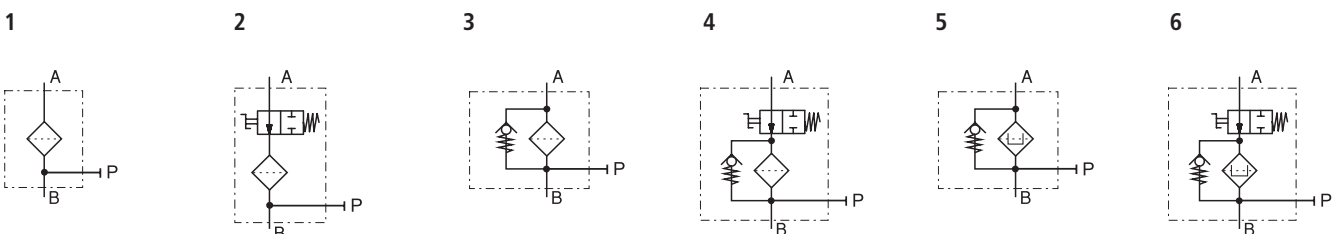

Spare Parts

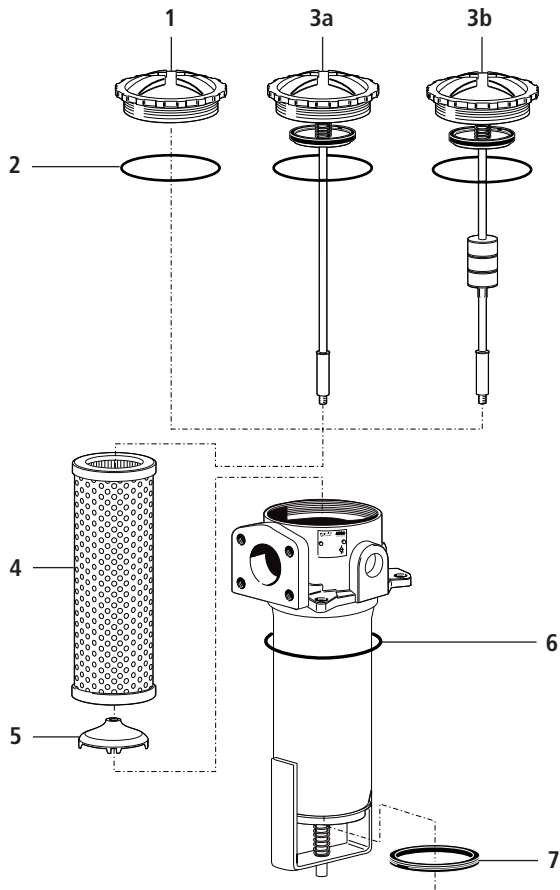

Pos.	Designation	Part No.
1	Screw-on cap with Pos. 2	ES 074.1212
2	O-ring 100 x 4	N 007.1004
3a	Screw-on cap assy with Pos. 2 ES 134 (without by-pass) ES 144 (without by-pass)	ES 074.1213 ES 094.1212
3b	Screw-on cap with Pos. 2 magnetic system ES 134 (with by-pass)	ES 074.1205
4	Filter element	see Chart / col. 10
5	Valve cone	ES 074.0202
6	O-ring 126 x 4 *	N 007.1264
7	Rubber ring	N 042.7401

* not included in basic equipment

The functions of the complete filters as well as the outstanding features of the filter elements assured by ARGO-HYTOS can only be guaranteed if original ARGO-HYTOS spare parts are used.

Quality Assurance

Quality management according to DIN EN ISO 9001

To ensure constant quality in production and operation, ARGO-HYTOS filter elements undergo strict controls and tests according to the following DIN and ISO standards:

DIN ISO 2941	Verification of collapse/burst resistance
DIN ISO 2943	Verification of material compatibility with fluids
DIN ISO 3724	Verification of flow fatigue characteristics

ISO 2942 ISO 3968 ISO 16889

Verification of fabrication integrity (Bubble Point Test)
Evaluation of pressure drop versus flow characteristics
Multi-Pass-Test (evaluation of filter fineness and dirt-holding capacity)

Various quality controls during the production process guarantee the leakfree function and solidity of our filters.

Our engineers will be glad to advice you in questions concerning filter application, selection as well as the cleanliness class of the filtered medium attainable under practical operating conditions.

Illustrations may sometimes differ from the original. ARGO-HYTOS is not responsible for any unintentional mistake in this specification sheet..



We produce fluid power solutions

ARGO-HYTOS GMBH · Industriestraße 9 · D-76703 Kraichtal

Tel: +49 7250 76-0 · Fax: +49 7250 76-199 · info.de@argo-hytos.com · www.argo-hytos.com