



Off-line Filter Units

FNA 008 • FNA 016

- Operating pressure up to 4 bar
- Nominal flow rate up to 16 l/min
- For tank capacities up to 1500 l

Description

Application

Off-line filtration in hydraulic and lubricating oil systems.

Performance features

Protection

against wear: By means of filter elements that meet even the highest demands regarding cleanliness classes and dirt-holding capacity.

Protection against

malfunction: By means of permanent filtration in the off-line circuits excellent cleanliness classes can be achieved. This can lead to significantly longer intervals between maintenance work and oil changes, as well as reduction of machine failures due to contamination.

Special design features

Cover: The cover can be opened without special auxiliary tools. Because of the cover design the filter element can be changed almost without losing any oil. No pipes are needed except for the connection lines. The power units feature minimal noise output and low power consumption.

Pressure

relief valve: An integrated PRV (pressure relief valve) protects against overload.

Dirt

retention valve: Ensures that dirt accumulated in the filter is removed together with the element. Settled dirt cannot return into the system.

Filter elements

Flow direction from centre to outside. The star-shaped pleating of the filter material results in:

- large filter surfaces
- low pressure drop
- high dirt-holding capacities
- long service life

Filter maintenance

By using a clogging indicator the correct moment for maintenance is stated and guarantees the optimum utilization of the filter life.

Materials

Pump housing: Aluminium alloy

Filter housing: Steel

Cover: Aluminium alloy

Seals: NBR (Viton on request)

Filter media: EXAPOR® - inorganic, multi-layer microfibre web

Accessories

Water-absorbing filter elements (EXAPOR® AQUA) are available on request.

With Part No. FNA 008.1700 a mounting set that facilitates the fitting of incoming and outgoing pipes onto an existing filling/venting connection is available.

For installation in filter cooling circuits a version with by-pass valve is available on request.

Electrical and optical clogging indicators are available.

Dimensions and technical data see catalogue sheet 60.20.

Characteristics

Nominal flow rate

Up to 16 l/min at $v = 35 \text{ mm}^2/\text{s}$
(see Selection Chart, column 2)

Connection

Threaded port according to ISO 228 or DIN 13.
Sizes see Selection Chart, columns 9 and 10

Filter fineness

$3 \mu\text{m(c)} \dots 12 \mu\text{m(c)}$

β -values according to ISO 16889

(see Selection Chart, column 3 and Diagram Dx)

Dirt-holding capacity

Values in g test dust ISO MTD according to ISO 16889
(see Selection Chart, column 5)

Hydraulic fluids

Mineral oil and biodegradable fluids
(HEES and HETG, see info-sheet 00.20)

Temperature range of fluids

$0 \text{ }^\circ\text{C} \dots +65 \text{ }^\circ\text{C}$ (also see viscosity range)

Ambient temperature range

$0 \text{ }^\circ\text{C} \dots +50 \text{ }^\circ\text{C}$

Viscosity range

Electro motor air cooled type of protection: IP 55	Continuous operation min.	Continuous operation max.	Short-term operation max.
3 ~ 400 V / 460 V	15 mm ² /s	200 mm ² /s	400 mm ² /s
1 ~ 230 V	15 mm ² /s	200 mm ² /s	400 mm ² /s
1 ~ 110 V	15 mm ² /s	100 mm ² /s	200 mm ² /s
24 V	15 mm ² /s	100 mm ² /s	150 mm ² /s

Tank capacity

approx. 2,4 l

Maximum suction height

1,5 m

Operating pressure

Max. 4 bar, pressure protection with pressure relief valve;
cracking pressure see Selection Chart, column 11

Operating position

Vertical, pump block at the bottom

Recommended tank capacities

FNA 008: 100 l ... 800 l

FNA 016: 400 l ... 1500 l

Off-line filter units for tank capacities exceeding 1500 l
see catalogue sheet 80.50

Selection Chart, columns 1-10

Part No.	Nominal flow rate	Filter fineness, see Diagr. Dx	Dirt-holding capacity	E-motor operating voltage	E-motor operating frequency (max.)	E-motor power (max.)	Engine speed at 50 Hz (max.)	Connection A Inlet	Connection B Outlet
	l/min		g	V	Hz	kW	min ⁻¹		
1	2	3	4	5	6	7	8	9	10
FNA 008-763	8	3 E-N	180	1 ~ 110 V	(60)	0,25 (0,3)	1400 (1700)	1 1/16-12UN2B	3/4-16UN-2B
FNA 008-163	8	5 E-N	180	1 ~ 110 V	(60)	0,25 (0,3)	1400 (1700)	1 1/16-12UN2B	3/4-16UN-2B
FNA 008-573	8	3 E-N	180	1 ~ 230 V	50	0,25	1400 (1700)	G 3/4	G 1/2
FNA 008-553	8	3 E-N	180	3 ~ 400 V/460 V	50 (60)	0,25 (0,3)	1400 (1700)	G 3/4	G 1/2
FNA 008-753	8	3 E-N	180	3 ~ 400 V/460 V	50 (60)	0,25 (0,3)	1400 (1700)	1 1/16-12UN2B	3/4-16UN-2B
FNA 008-153	8	5 E-N	180	3 ~ 400 V/460 V	50 (60)	0,25 (0,3)	1400 (1700)	G 3/4	G 1/2
FNA 008-556	8	12 E	85	3 ~ 400 V/460 V	50 (60)	0,25 (0,3)	1400 (1700)	G 3/4	G 1/2
FNA 016-763	16	3 E-N	160	1 ~ 110 V	(60)	(0,3)	2800 (3300)	1 1/16-12UN2B	3/4-16UN-2B
FNA 016-163	16	5 E-N	160	1 ~ 110 V	(60)	(0,3)	2800 (3300)	1 1/16-12UN2B	3/4-16UN-2B
FNA 016-573	16	3 E-N	160	1 ~ 230 V	50	0,45	2700 (3200)	G 3/4	G 1/2
FNA 016-173	16	5 E-N	160	1 ~ 230 V	50	0,45	2700 (3200)	G 3/4	G 1/2
FNA 016-553	16	3 E-N	160	3 ~ 400 V/460 V	50 (60)	0,45 (0,55)	2700 (3200)	G 3/4	G 1/2
FNA 016-753	16	3 E-N	160	3 ~ 400 V/460 V	50 (60)	0,45 (0,55)	2700 (3200)	1 1/16-12UN2B	3/4-16UN-2B
FNA 016-153	16	5 E-N	160	3 ~ 400 V/460 V	50 (60)	0,45 (0,55)	2700 (3200)	G 3/4	G 1/2
FNA 016-773	16	5 E-N	160	3 ~ 400 V/460 V	50 (60)	0,45 (0,55)	2700 (3200)	1 1/16-12UN2B	3/4-16UN-2B
FNA 016-6553	16	3 E-N	160	24 V DC	–	0,25	2820	G 3/4	G 1/2
FNA 016-193	16	5 E-N	160	24 V DC	–	0,25	2820	G 3/4	G 1/2

Diagrams

Filter fineness curves in Selection Chart, column 3

Dx

Filtration ratio β as a function of particle size x obtained by the Multi-Pass Test according to ISO 16889

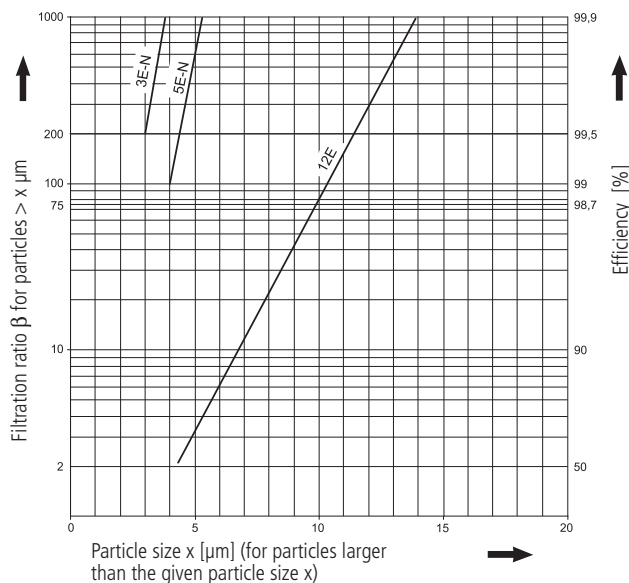

The abbreviations represent the following β -values resp. finenesses:

For EXAPOR®-elements:

3 E-N = $\bar{\beta}_{3(c)}$ = 200 EXAPOR®
5 E-N = $\bar{\beta}_{5(c)}$ = 200 EXAPOR®
12 E = $\bar{\beta}_{12(c)}$ = 200 EXAPOR®

For special applications, finenesses differing from these curves are also available by using special composed filter media.

Selection Chart, columns 11-17

Part No.	Cracking pressure of by-pass	Symbols hydraulic	Symbols electric	Measurements, Type No.	Replacement filter element Part No.	Clogging indicator	Remarks
bar	11	12	13	14	15	16	17
FNA 008-763	4	1	3	2	V7.1220-113	optional	
FNA 008-163	4	1	3	2	V7.1220-13	optional	
FNA 008-573	4	1	3	1	V7.1220-113	optional	
FNA 008-553	4	1	1, 2	1	V7.1220-113	optional	
FNA 008-753	4	1	1, 2	2	V7.1220-113	optional	
FNA 008-153	4	1	1, 2	1	V7.1220-13	optional	
FNA 008-556	4	1	1, 2	1	V7.1220-06	optional	
FNA 016-763	4	1	3	2	V7.1220-113	optional	
FNA 016-163	4	1	3	2	V7.1220-13	optional	
FNA 016-573	4	1	3	1	V7.1220-113	optional	
FNA 016-173	4	1	3	1	V7.1220-13	optional	
FNA 016-553	4	1	1, 2	1	V7.1220-113	optional	
FNA 016-753	4	1	1, 2	2	V7.1220-113	optional	
FNA 016-153	4	1	1, 2	1	V7.1220-13	optional	
FNA 016-773	4	1	1, 2	2	V7.1220-13	optional	
FNA 016-6553	4	1	4	3	V7.1220-113	optional	
FNA 016-193	4	1	4	3	V7.1220-13	optional	

All filter units are delivered with an unplugged clogging indicator connection M12 x 1,5. As clogging indicators either manometers or electrical pressure switches can be used.

For the appropriate clogging indicators see catalogue sheet 60.20.

By the use of a manometer version DG 200-16* has to be chosen.

Remarks:

- If operating frequency increases, pump delivery will increase as well.
- The filter units listed in this chart are standard units. If modifications are required, e.g. with water-absorbing filter elements, pipe extensions or mounting sets, we kindly ask for your request.
- The clogging indicators are optionally available and then will be loosely provided.

* Manometer without throttle screw

Dimensions

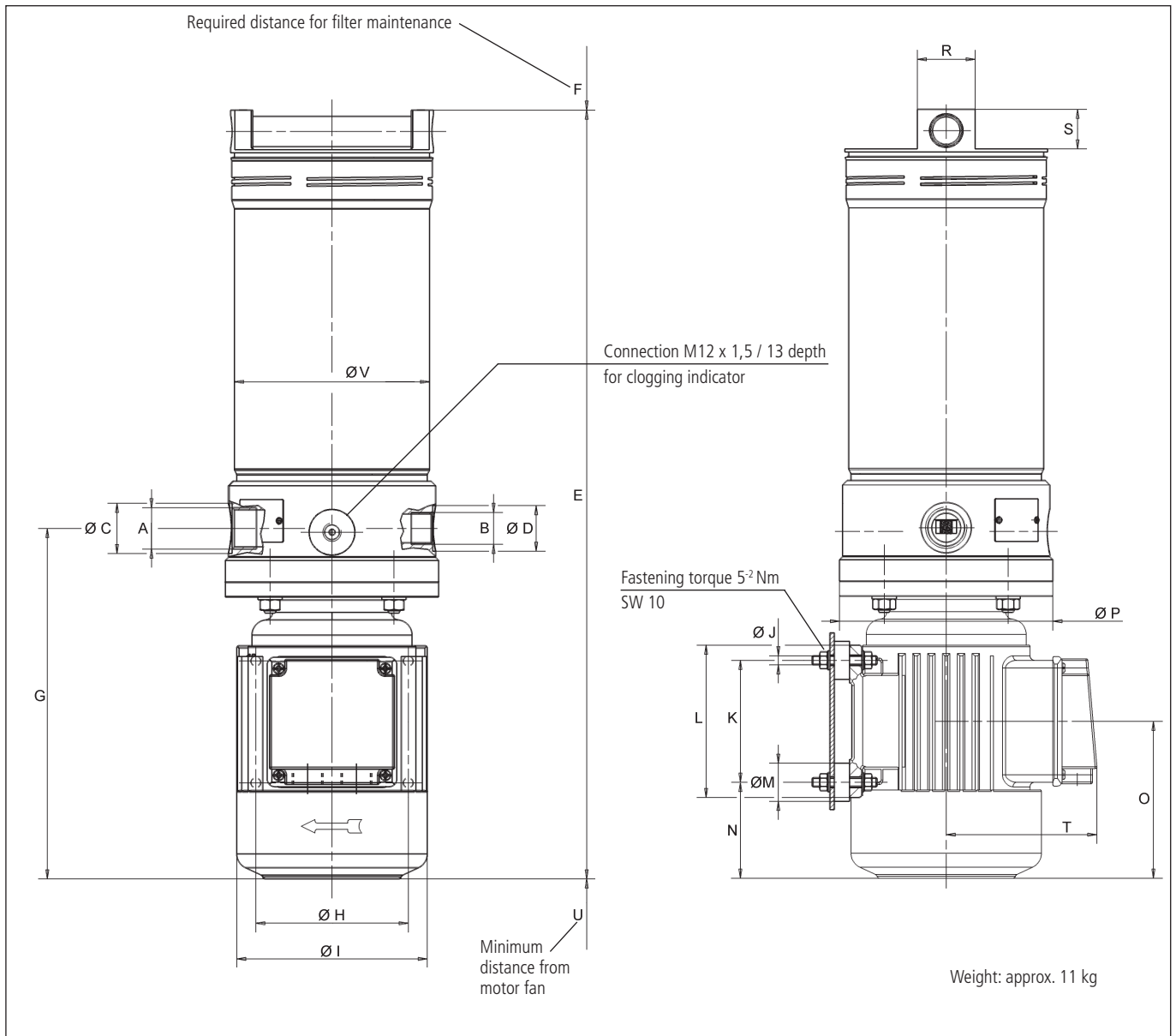

Measurements

Type*	A	B	C	D	E	F	G	H	I	J	K	L	M	N	O	P	R	S	T	U	V
1	G3/4	G1/2	33	30	510	340	230	100	125	M6	80	100	25	63	105	140	38,5	27	100	20	128
2	1 1/16-12UN2B	3/4-16UN-2B	33	30	510	340	230	100	125	M6	80	100	25	63	105	140	38,5	27	100	20	128
3	G3/4	G1/2	33	30	550	340	265	100	125	M6	80	100	25	105	145	140	38,5	27	100	20	128

*Type see Selection Chart, column 14

Symbols

Hydraulic:

1

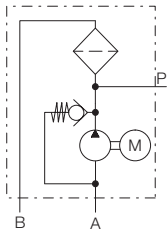

Electric:

1

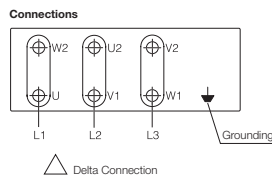

2

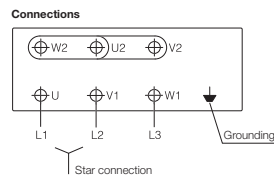

3

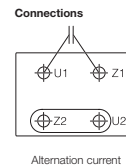

4

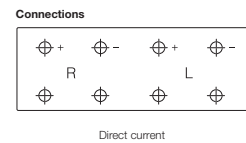

Quality Assurance

Quality management according to DIN EN ISO 9001

To ensure constant quality in production and operation, ARGO-HYTOS filter elements undergo strict controls and tests according to the following DIN and ISO standards:

- DIN ISO 2941** Verification of collapse/burst resistance
- DIN ISO 2943** Verification of material compatibility with fluids
- DIN ISO 3724** Verification of flow fatigue characteristics

ISO 2942 ISO 3968 ISO 16889

Verification of fabrication integrity (Bubble Point Test)
Evaluation of pressure drop versus flow characteristics
Multi-Pass-Test (evaluation of filter fineness and dirt-holding capacity)

Various quality controls during the production process guarantee the leakfree function and solidity of our filters.

Our engineers will be glad to advice you in questions concerning filter application, selection as well as the cleanliness class of the filtered medium attainable under practical operating conditions.

Illustrations may sometimes differ from the original. ARGO-HYTOS is not responsible for any unintentional mistake in this specification sheet.



We produce fluid power solutions

ARGO-HYTOS GMBH · Industriestraße 9 · D-76703 Kraichtal

Tel: +49 7250 76-0 · Fax: +49 7250 76-199 · info.de@argo-hytos.com · www.argo-hytos.com