

## Particle Monitor

### OPCom

- With laser diode
- Measurement range 4, 6, 14 and 21 µm(c)
- Operating pressure up to 500 bar

## Description

### Application

As stationary particle monitor in hydraulic and hydrostatic lubrication systems.

### Performance features

Protection: By continuous controlling of the oil cleanliness, damage can already be recognized in the early stage. This offers the possibility of avoiding machine faults by suitable measures and of extending maintenance and oil change intervals.

### Special design features

Modular

Construction: The particle monitor consists of a sensor module and a communication module.  
The sensor module is selected according to the pressure and viscosity conditions in the working range, the communication module is chosen according to the requirements for data processing. Each sensor module is optionally also available with a display, from which the degrees of purity can be read off according to ISO 4406:1999.

### Measurement

principle:

The particle monitor operates according to the light extinction principle. The oil flows through the sensor with system pressure and approx. 50 ... 500 ml/min. It is analyzed by a laser. Opposite of the laser a photodiode measures the weakening of the light with presence of a particle and calculates from it the particle size and number. For the tuning of the monitor on different pressure and viscosity ranges different variations of the sensor are selectable. For the installation of the particle monitor particularly lines are suitable in which no large pressure fluctuations and pressure peaks occur, like e. g. pilot oil lines.

### Standard Accessories

DDE-Software  
Optical fibre optic cable, 6 m  
Operating instructions

Under the designation OPCom portable a portable on-line monitor is available, with which by connection to a computer the measuring data can also be plotted and filed. For dimensions and technical data see brochure OPCom portable.

## Technical Data

|                                |   |
|--------------------------------|---|
| Size channels                  | 4, 6, 14, 21 µm(c)  |
| Display                        | Cleanliness classes according to ISO 4406:1999 with additional decimal  |
| Concentration limit            | Class 29 according to ISO 4406:1999   |
| Operating pressure             | 9 ... 36 VDC at approx. 150 mA charging rate  |
| Fluid pressure                 | max. 500 bar  |
| Temperature range              | -20 °C ... +80 °C   |
| Viscosity range                | > 2 mm <sup>2</sup> /s  |
| Ambient conditions operation   | -20 °C ... +60 °C, 20 ... 95% rel. humidity, non condensing   |
| Ambient conditions storing     | -40 °C ... +85 °C, < 98% rel. humidity, non condensing  |
| Dimensions System with display | LxWxH: 9.4 x 8.7 x 4.6 cm   |
| System without display         | LxWxH: 9.4 x 8.7 x 3.6 cm   |
| Weight System with display     | 1.28 kg   |
| System without display         | 1.26 kg   |
| Hydraulic fluids               | Mineral oils and biodegradable fluids (HEES, HETG...)<br>On request: Phosphate ester (e.g. Skydrol)   |
| Wetted materials               | SAE 1020 steel, spring steel, synthetic sapphire, chrome, zinc, bronze, aflas, Buna-N<br>Attention: Sensors for Skydrol do not contain Buna-N |

## Diagrams

### Viscosity diagrams / permitted ranges for different sensor versions (see order terms)

Viscosity as a function of the **pressure** (within working range)

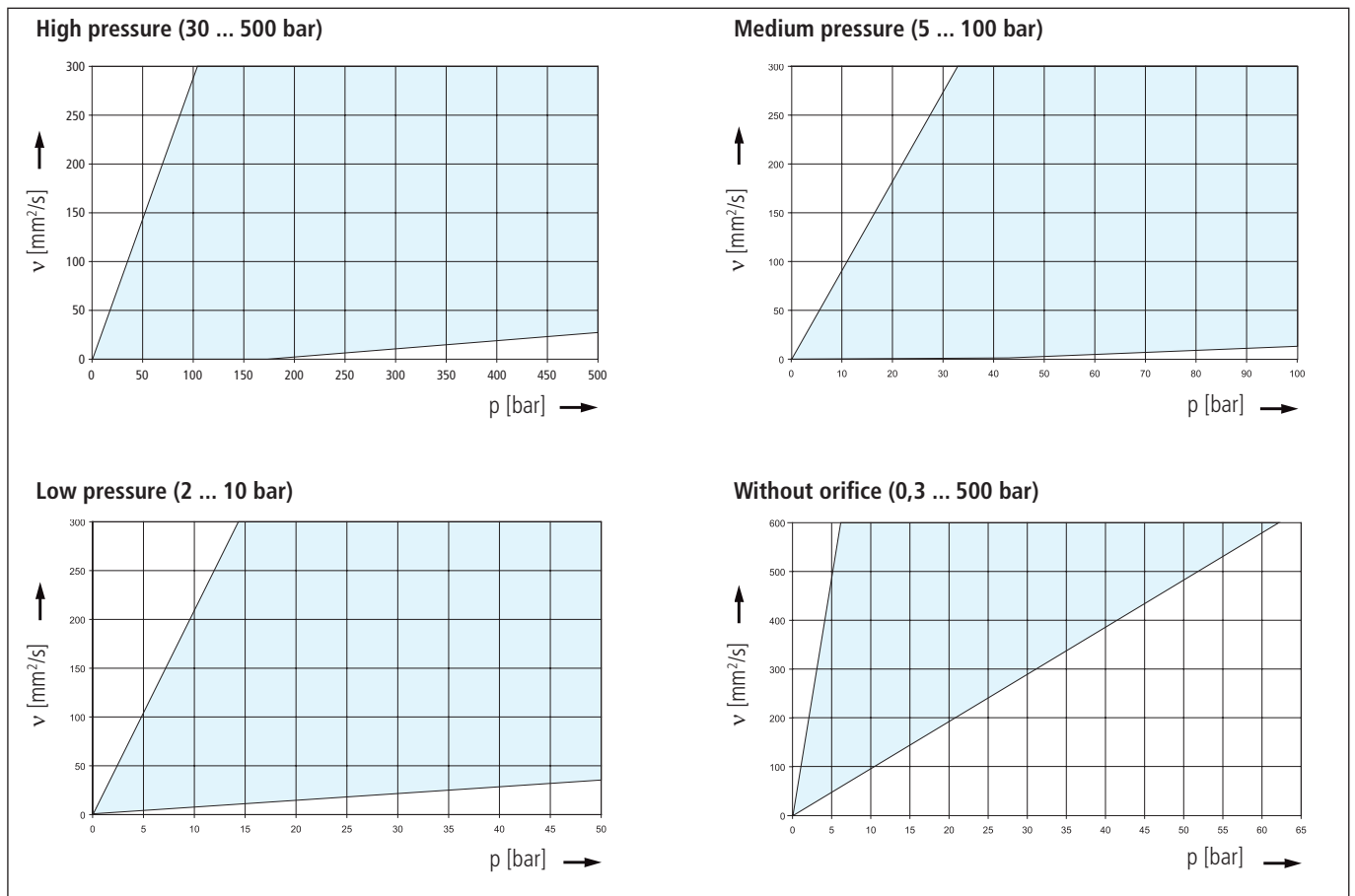

## Communication Interface Description



Configuration only possible by infrared interface (IrDA).

Data recording by computer or data logger over the following interfaces:

- RS-232 standard
- Data logger or PLC systems:
  - 8 channels with in each case 0 - 5 VDC analogue output
- RS-485 with MODBUS record for operation in the network
- Separate indication with programmable alarm limit and floating contact
- Data memory with power supply unit

### Splitting of the optical fiber

The use of multiple communication modules at the same time is possible. The light signal is split by means of a splitter and is fed to both modules. At short distances (up to 8 m) a simple line split with a passive splitter

is sufficient (order no. 16319600), with longer lines the use of an active splitter is necessary, which receives and strengthens the signals (order no. 16319800).

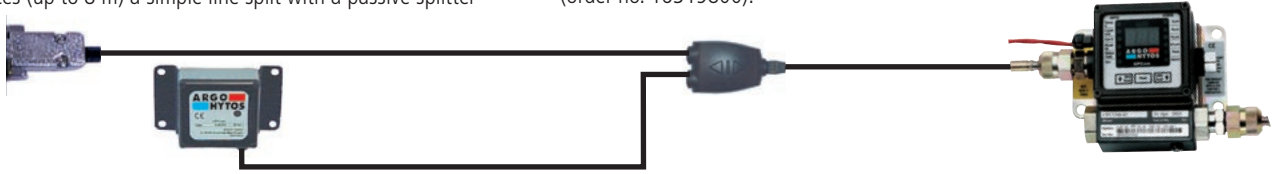

### Memory module with power supply unit for power supply of OPCom

The data memory offers capacity for more than 500 readings. Every reading is set with the date and time. In that way it is always possible

to trace back when the data was recorded. At the same time the power supply unit offers the power supply for OPCom of 12 VDC at an input voltage of 100-250 VAC.

## Order Terms

The selection of the suitable OPCom takes place in two steps:

1. Definition of the sensor module and the indication
2. Selection of the communication version

For the selection of the sensor module viscosity and pressure in the work area must be known. By means of these parameters the suitable version can be selected on the basis of the permissible ranges in the diagrams.

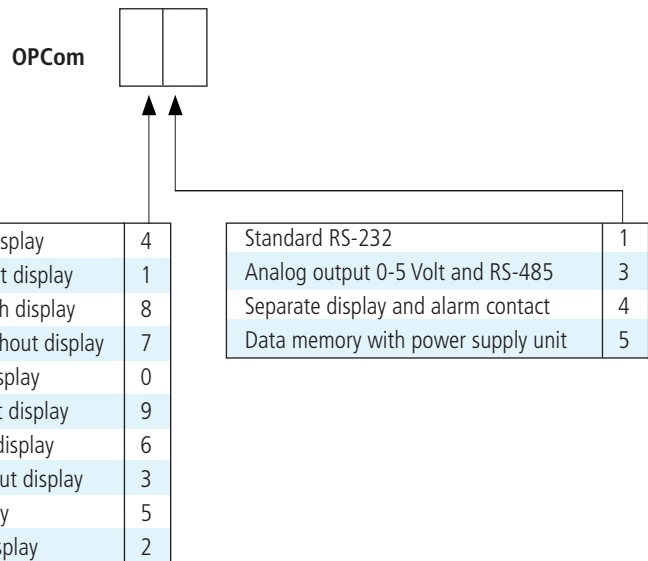

## Quality Assurance

### Quality management according to DIN EN ISO 9001

Various quality controls during the production process guarantee the leakfree function and solidity of our filters.

Our engineers will be glad to advice you in questions concerning filter application, selection as well as the cleanliness class of the filtered medium attainable under practical operating conditions.

Illustrations may sometimes differ from the original. ARGO-HYTOS is not responsible for any unintentional mistake in this specification sheet.



### We produce fluid power solutions

ARGO-HYTOS GMBH · Industriestraße 9 · D-76703 Kraichtal

Tel: +49 7250 76-0 · Fax: +49 7250 76-199 · info.de@argo-hytos.com · www.argo-hytos.com