



## LITHIUM SERIES® II Electric Torque Tool

The LITHIUM SERIES II Electric Torque Tool is the next revolution in bolting technology redesigned from the ground up with expanded functionality, greater durability, and intuitive usability. This lightweight 36-Volt battery-powered tool, with capacity up to 5,000 ft-lbs, is the ultimate solution for strength and portability in industrial bolting jobs worldwide. This tool is compatible with conventional sockets, the HYTORC Washer, and the HYTORC Nut.

### EXPANDED FUNCTIONALITY



The LITHIUM SERIES II Tool incorporates TorcSense™ Technology which directly measures torque providing more repeatable results. Now available in a 5,000 ft-lbs configuration expanding the operational capability of this tool. With all new features such as the sliding directional switch, snug function, user access levels, advanced bolting, and more further extends the versatility of the tool.

### GREATER DURABILITY



The nickel plated all-aluminum housing greatly improves corrosion resistance and overall durability. The all new 36V brushless motor has more than 5 times longer life than its predecessor. Gearboxes are redesigned for 20% greater strength and reliability. The integrated rear cover shock guard absorbs impact protecting the display and buttons. Hall Effect trigger and directional switches increases dependability.

### INTUITIVE USABILITY



The user interface and menu structure is remodeled for ease of use while presented on a high resolution display. Settings menu offers finer control of user preferences. Expansion of job data management provides flexibility in verifying work performed. Now standard with Bluetooth wireless technology makes data acquisition and firmware upgrades easier than ever. The work light and side handle further enhance safety and productivity.

# ELECTRIC

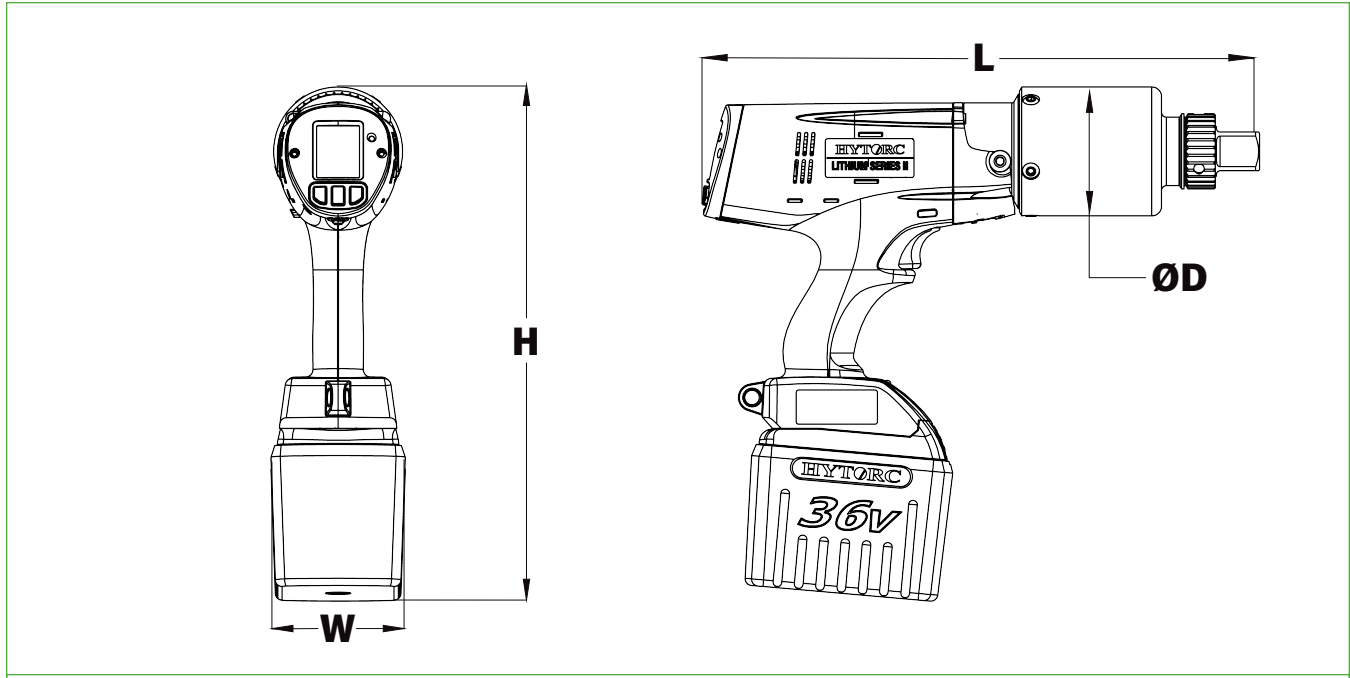

**LEGEND:** H = HEIGHT W = WIDTH L = LENGTH ØD = DIAMETER

CONFIGURATIONS	H	W	L	D	SQUARE DRIVE	WEIGHT W/ BATTERY	SNUG		TORQUE	
							ft-lbs (Min)	ft-lbs (Max)	ft-lbs (Min)	ft-lbs (Max)
<b>IMPERIAL</b>										
	in.					lbs.	ft-lbs (Min)	ft-lbs (Max)	ft-lbs (Min)	ft-lbs (Max)
<b>LST-0700</b>	12.9	3.5	11.4	2.6	3/4	11.7	35	149	150	700
<b>LST-1200</b>	12.9	3.5	11.7	2.6	3/4	12.0	60	199	200	1,200
<b>LST-2000</b>	13.2	3.5	13.9	3.2	1	16.6	100	324	325	2,000
<b>LST-3000</b>	13.3	3.5	14.4	3.4	1	17.7	150	499	500	3,000
<b>LST-5000</b>	16.6	4.0	15.4	4.0	1-1/2	22.4	200	799	800	5,000
<b>METRIC</b>										
	mm				in.	kg	Nm (Min)	Nm (Max)	Nm (Min)	Nm (Max)
<b>LST-0700</b>	328	89	290	66	3/4	5.3	47	202	203	949
<b>LST-1200</b>	328	89	297	66	3/4	5.5	81	270	271	1627
<b>LST-2000</b>	335	89	353	81	1	7.5	135	439	440	2712
<b>LST-3000</b>	338	89	366	86	1	8.0	203	676	677	4067
<b>LST-5000</b>	422	102	391	102	1-1/2	10.2	270	1083	1085	6779

## COMPLETE KIT CONTENTS

- LITHIUM SERIES II Tool
- Reaction Arm
- Storage Case
- 36V Battery
- Battery Charging System
- Side Handle
- Calibration Certificate
- Operation Manual

## LST

### Model:

LITHIUM SERIES TOOL

### Capacity:

Available: 0700, 1200,  
2000, 3000, 5000

### Communication:

Blank: Bluetooth Communication  
U: USB Only

### Examples:

1. LST-0700 standard tool, 700 ft-lb capacity, with Bluetooth Communication
2. LST-0700-U standard tool, 700 ft-lb capacity, without Bluetooth - USB Connection Only

HYTORC owns all content, copyrights, trademarks and patents in this document. © 2022 HYTORC. Any unauthorized use or distribution of any material from this document is strictly prohibited.



**Headquarters:**  
333 Route 17 N., Mahwah, NJ 07430  
+1-201-512-9500

**Email:**  
info@hytorc.com

**Phone:**  
1-800-FOR-HYTORC

**Online:**  
hytorc.com