

Center Hole CYLINDERS RH SERIES

30-200 Ton Double-Acting

Ideal for pulling and tensioning of cables, anchor bolts, forcing screws.

CYLINDERS

- Interchangeable piston head inserts (see page 41) provide versatility of application.
- Built-in safety feature prevents over-pressurization of the retract circuit.
- Plated piston rod resists wear; superior packings provide high cycle life without leakage.
- Corrosion-resistant standpipe has "Power Tech" treatment (see page 8).
- Each cylinder has 9796 3/8" NPTF female half couplers. The 60 ton thru 200 ton steel models are equipped with removable carrying handles.



ASME B30.1
700 BAR



30, 60, 100 Ton
Double-Acting Models Feature
Threaded Collar

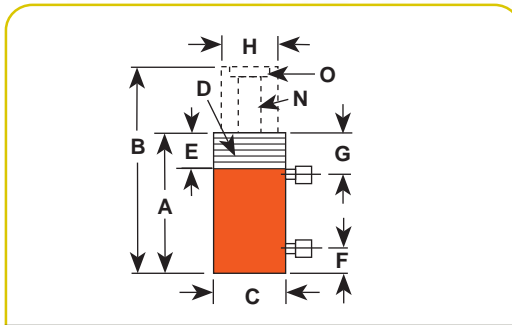

Cyl. Cap. (tons)	Stroke (mm)	Order No.	Oil Cap. (cm ³)		A	B	C	D	E	F	G	H	N	Insert Thread (in.)	Mounting Bolt Circle (mm)	Cylinder Effective Area (cm ²)		Metric Tons at 700 bar		Weight (kg)		
			Push	Pull												Push	Pull	Push	Pull			
30	15	76,2	RH303	289	167	179,4	255,6	120,7	-	-	25,4	41,3	63,5	32,5	2-12	3/16 x 92,1	38,0	21,8	26,8	15,3	13,5	
30	15	152,4	RH306D	580	333	281,0	433,4	120,7	-	-	25,4	41,3	63,5	32,5	2-12	1/8-20 x 92,1	38,0	21,8	26,8	15,3	20,4	
30	20	257,2	RH3010	1.082	672	438,2	695,3	114,3	4 1/2-12	41	44,5	81,0	60,3	33,3	1 1/2-16	-	42,2	26,1	29,7	18,3	27,7	
60	25	101,6	RHA604D	807	338	241,3	342,9	177,8	-	-	39,7	57,2	101,6	54,0	3-12	1/2-13 x 130,2	79,4	33,2	55,8	25,1	16,2	
60	25	127,0	RH605*	1.009	423	241,3	368,3	165,9	-	-	25,4	44,5	101,6	54,0	3-12	1/2-13 x 130,2	79,4	33,2	55,8	25,1	33,1	
60	40	257,2	RH6010*	2.181	1.427	458,8	716,0	158,8	6 1/2-12	47,6	54,0	81,8	92,1	54,4	3-16	-	84,8	55,4	59,6	38,9	54,5	
100	45	38,1	RH1001*	526	233	165,1	203,2	212,7	-	-	31,8	58,7	127,0	79,8	4-16	5/8-11 x 177,8	138,0	60,8	97,0	42,7	38,6	
100	50	152,4	RH1006*	1.971	1.076	314,3	466,7	184,2	-	-	37,3	59,1	111,1	52,4	-	1/2-13 x 139,7	129,2	70,5	90,8	49,6	43,1	
NEW	100	45	257,2	RHA1008D	Contact factory for details and availability																	
	100	45	257,2	RH10010*	3.552	1.556	495,3	752,5	215,9	8 1/2-12	57	63,5	91,7	139,7	79,8	4 1/2-12	-	138,0	60,8	97,0	42,7	109,0
	150	70	127,0	RH1505*	2.475	1.207	311,2†	438,2	215,9	-	-	37,3	68,3	139,7	65,1	-	-	194,1	94,8	136,9	66,8	67,2
	150	75	203,2	RH1508*	3.929	2.086	349,3	552,5	247,7	-	-	39,3	61,1	152,4	80,2	5-12	-	193,2	102,6	135,9	72,1	103,1
NEW	150	75	203,2	RHA1508D*	Contact factory for details and availability																	
	200	75	203,2	RH2008*	5.307	2.093	408,0	611,2	273,1	-	-	57,2	81,8	190,5	103,2	6-12	1 1/2-12 x 198,1	260,9	102,9	183,5	72,4	142,0
NEW	200	75	203,2	RHA2008D*	Contact factory for details and availability																	

* Supplied with carrying handles.

† Measured with 19 mm high serrated insert installed.
See pages 36-41 & 120-133 for hydraulic accessories.

Aluminum

