

WBE 510

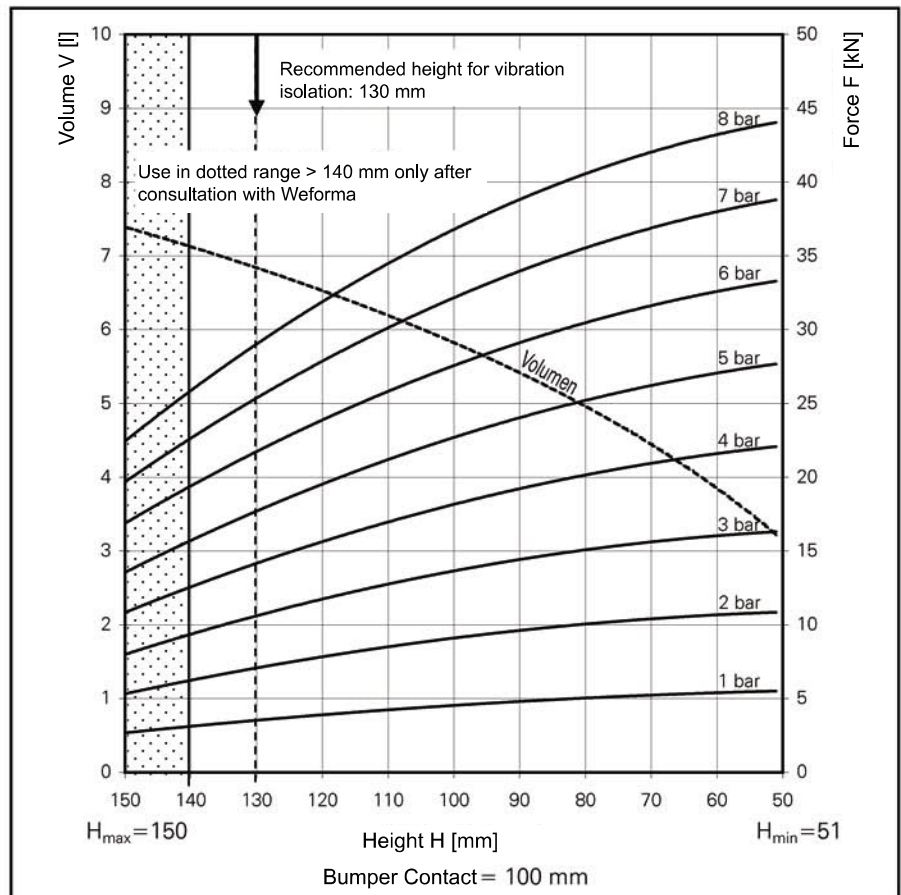
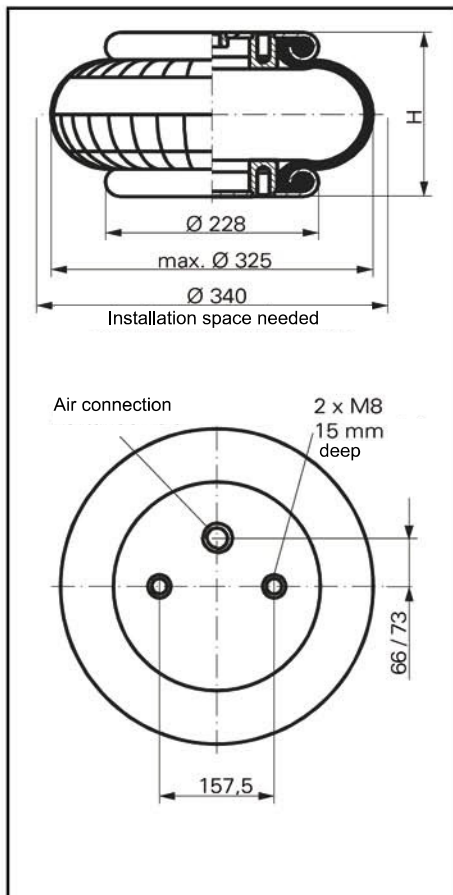

Force-height diagramm

Air connection

WBE 510-E1 G1/4

Technical data

Min. pressure	0 bar
Return force to min. height	≤ 300 N
Overall weight with clamped plates	4,1 kg

Vibration isolation - dynamic characteristic values

Design height empf. 130mm, minimal 100mm

Pressure p [bar]	3	4	5	6	7	8	Vol. V [l]
Force (Load) [kN]	10,7	14,2	17,8	21,8	25,4	29,0	6,8
Spring rate c [N/cm]	2645	3290	3935	4580	5225	5870	
Natural frequenz f0 [Hz]	2,5	2,4	2,4	2,3	2,3	2,3	

Pneumatic application - static characteristic values

Force F [kN]

Pressure p [bar]	3	4	5	6	7	8	Vol. [l]	
Height H [mm]	130	10,7	14,2	17,8	21,8	25,4	29,0	7,0
	120	11,9	15,7	19,6	23,8	27,8	31,8	6,3
	110	12,7	16,9	21,1	25,8	30,1	34,4	5,8
	100	13,6	18,1	22,7	27,6	32,1	36,7	5,6
	90	14,4	19,2	24,0	29,1	34,0	38,9	5,3
	80	15,0	20,2	25,2	30,5	35,5	40,6	4,9
	70	15,5	20,9	26,2	31,6	36,9	42,1	4,3
	60	16,0	21,6	27,1	32,6	38,0	43,3	3,9



Service instructions

M8 = 25 Nm

G 1 = 50 Nm

G 1/4 = 25 Nm